

*COMMERCIAL
ELECTRIC SERVICE
and
METER INSTALLATION
HANDBOOK*

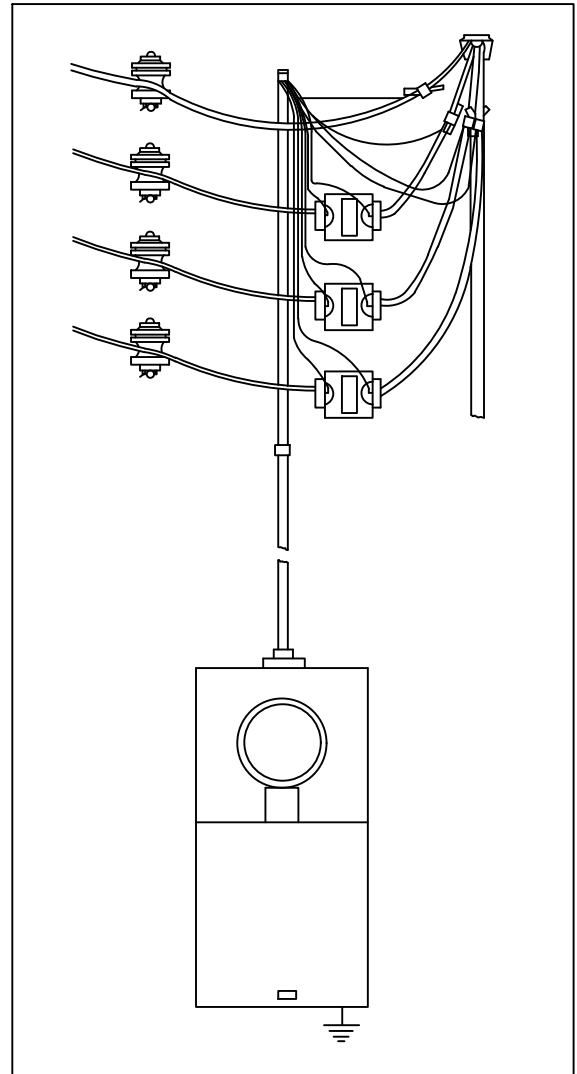

Alabama
Power



NOTICE:
THIS DOCUMENT IS SUBJECT TO CHANGE AT ANY TIME.

COPYRIGHT NOTICE: Copyright © 2016 Southern Company. All Rights Reserved.

All materials are the copyrighted property of Southern Company, its subsidiaries, affiliated companies and/or third-party licensors. All trademarks, service marks, and trade names are proprietary to Southern Company, or its subsidiaries or affiliated companies and/or third-part licensors.

The materials may not modified, copied, distributed, transmitted, displayed, performed, reproduced, published, licensed, nor derivative works created, without the expressed, written permission from Southern Company.

TABLE OF CONTENTS

Section	Page Number
I INTRODUCTION	1
II GENERAL INFORMATION	2
A. Definitions	2
B. Availability and Location of Service	3
C. Application for Service	3
D. Type and Character of Service	3
E. Inspection	4
F. Alterations and Additions	5
G. Customer's Responsibilities	5
H. Refusal or Discontinuance of Service by the Company	5
I. Interruption and Liability	6
III SERVICES	7
A. General Information	7
B. Temporary Service	7
C. Overhead Services	8
D. Underground Services	8
IV METERING INSTALLATIONS	9
A. General Requirements	9
B. Meter Location	10
C. Instrument Transformer Installations	11
V EQUIPMENT VAULTS	12
A. General Requirements	12
B. Customer Responsibilities	12
C. Company Responsibilities	12
VI CUSTOMER UTILIZATION EQUIPMENT	13
A. General	13
B. Motors	13
C. Special Equipment	14

SECTION I

INTRODUCTION

Alabama Power Company constantly strives to maintain a high standard of service to all customers. This booklet has been issued for use by customers, architects, engineers, electrical contractors, and local inspection authorities when planning new electrical installations, repairing or renewing existing installations, or adding additional equipment. Copies are available in all Alabama Power Company business offices.

All holders of Electrical Service and Meter Installations booklets are encouraged to submit proposals to aid in future revisions. Please submit proposals as follows:

1. Give section, paragraph, and page number to which proposal pertains.
2. Submit proposal in writing giving details, sketches, drawings, and all supporting pertinent information.
3. Mail to: Alabama Power Company
Distribution Engineering Services
P. O. Box 2641
Birmingham, Al. 35291-0715

The practices discussed in this booklet are supplementary to and do not intentionally conflict with the National Electrical Code or such state and municipal laws and ordinances as may be in force within the cities, towns, or communities in which the Company furnishes electric service.

It is necessary to always refer to and comply with statutes, Alabama Public Service Commission rules, and local ordinances. The information contained herein is general and does not include every detail or every lawful requirement.

Except for the installation and maintenance of its own property, Alabama Power Company does not install or repair wiring to customer's premises and, therefore, is not responsible for the voltage beyond the point of delivery and does not assume any responsibility for, or liability arising because of the condition of wires or apparatus on the premises of any customer beyond the point of delivery.

The Company desires to serve its customers promptly and satisfactorily. It will endeavor to cooperate with customers and contractors to the fullest extent in completing service connections with as little delay and inconvenience as possible.

The Company will be pleased to confer with those desiring information concerning rates, services, etc., upon request by telephone or otherwise.

SECTION II

GENERAL INFORMATION

A. DEFINITIONS

The following definitions will apply for terms used in this booklet.

Company: The Alabama Power Company

Customer: User of the Company's electric service or his authorized representative (architect, electrical engineer, electrical contractor, etc.)

Demand: The rate at which electric energy is consumed per time interval, measured in KW, KVA or KVAR. Alabama Power Company uses a 15 minute interval length.

Inspector or Inspection Authority: A person or agency authorized by a governmental body to inspect and approve electrical installations.

Maximum Available Fault Current (at point of delivery): The maximum current that would flow due to a direct short from one conductor to ground or between conductors.

National Electric Code (NEC): A code sponsored by the National Fire Protection Association for the purpose of safeguarding persons and property from hazards arising from the use of electricity.

Service: The supply by the Company of electricity to the Customer, including the readiness and availability of electrical energy at the Customer's Point of Delivery at the standard available voltage and frequency whether or not utilized by the Customer.

Service Drop: The overhead service conductors from the last pole or other aerial support to and including the splices, if any, connecting to the service entrance conductors at the building or other structure.

Service Entrance: Customer owned wire and enclosures, connecting the Customer's service equipment to the Company's service drop, service lateral, transformer bushings, or other source of supply.

Service Lateral: The underground service conductors between the secondary conductors or transformers, including any risers at a pole or other structure, and the first point of connection to the service entrance conductors.

Point of Delivery: The point of attachment where the Company's service drop, service lateral, or transformer secondary bushings is connected to the Customer's service entrance conductors.

Nominal: The approximate value that is expected to normally exist when measured.

Ground Rod, Ground Electrode: A metal rod that is driven into the earth to provide a proper connection between the electrical circuit and the earth.

Ground Wire, Ground Conductor: A metal conductor that connects the grounding electrode to the electrical circuit.

Meter Socket, Meter Trough, Meter Base: A metal enclosure that holds the Alabama Power Company meter.

B. AVAILABILITY AND LOCATION OF SERVICE

1. Alabama Power company has every intention of meeting any Customer requirements in regards to your projected service date. If the Customer will contact the Company well in advance of the date the actual service connection is required, then his or her desires as well as the Company's, will be met with satisfaction. The Customer should contact the local engineering office to work with the Company on such matters as the type service available, the point of delivery, voltage, phase, etc., as these characteristics may vary in different locations.
2. The Company will make extensions to its existing facilities when serving its customers. These extensions will be to the point most beneficial to the Customer and the Company. Should any additional facilities be requested by the Customer, the Customer may be required to pay an additional cost.
3. Before construction is started, the Customer and the Company, shall agree on a point of delivery, and the appropriate load data. The point of delivery shall include the locations of such equipment as meters, risers, pedestals, pull boxes, CT cabinets, etc. The load data should include the type and number of electrical appliances to be used, and when possible, a set of building plans. The request for point of delivery location is not an application for service to the permanent building.

C. APPLICATION FOR SERVICE

1. The customer should apply for service **on-line or call (888) 430-5787.** Service contracts and/or deposits may be required prior to service connection.
2. Customers or perspective customers should advise the Company of new installations as early as possible in order that details for furnishing service may be worked out and necessary materials assembled. This will help to avoid delay in providing service at the desired time. The Customer shall provide, free of expense to the Company, suitable locations and space for the transformer, meters and other equipment of the Company which are necessary to supply service.
3. Application for service must include street and house number, zip code or if in a rural territory other information to assist in locating Customer's premises.

D. TYPE AND CHARACTER OF SERVICE

1. It is essential that the customer consult the Company regarding type of service which can be furnished at a particular location before proceeding with purchase of equipment or installation of wiring.
2. Service is provided with alternating current at a nominal frequency of sixty (60) hertz (cycles).
3. The voltage and/or the number of phases which will be supplied will depend on the type, size, and location of the load, and existing Company facilities.

A. Voltage

- (1) The standard voltage is 120/240, 120/208, and 277/480 nominal. Only one of these sets of voltages is normally available at any given location. If a voltage is requested other than that which is currently established at the desired location, the Customer should contact the Company to determine what is available.
- (2) If the load requires only 120 volt two-wire service, the Company will provide 120/240 volt three-wire service to the service entrance. The customer must provide three-wire service entrance conductors to the meter socket. It is not necessary for the three-wire service to be extended beyond the meter socket.

B. Phase

Single phase three wire service or three phase, four wire service will be provided according to the following:

- (1) In multi occupancy buildings or complexes served by 120/208 volt, three phase facilities, normal service to individual occupancies will be 120/208 volt single phase three wire. Three phase, four wire service to such customers will be supplied if the required Company facilities are readily available.
- (2) Commercial/Industrial customers located in commercial/industrial area will be provided three phase service if it is currently available at the location.
- (3) If three phase service is requested and the above conditions are not satisfied, the Customer may be required to pay additional cost.
- (4) The manner in which single phase load is connected by the customer is critical with three phase service. On 120/208 volt or 277/480 volt "wye" three phase services, all single phase load should be split evenly among the three phases. On 120/240 volt "delta" three phase services, all single phase load, both 120 volt and 240 volt, shall be connected only to the 120 volt-to-ground legs. No single phase load shall be connected to the "power phase". Connections made otherwise may result in a overload or single phase condition with the possibility of damage to the customer's three phase equipment. Arrangements for delta connected metering are shown in Plate C-09-01.
- (5) The information contained in this booklet refers primarily to service requirements at the usual secondary voltages (less than 600 volts). Service requirements requiring higher distribution voltages are subject to special arrangements between the Company and the Customer.

E. INSPECTION

1. The Customer's wiring and electrical equipment shall be installed and maintained in accordance with the latest edition of the National Electrical Code and any state and local ordinances.
2. All wiring installations must be inspected and approved by an authorized electrical inspector, where available. The Company can make connection only when requirements of this booklet have been met, and the installation has been approved by the authorized inspecting authority, where available.
3. The Company will refuse service to any new or altered installation which the Company considers unsafe. The Company may disconnect a service that shows physical evidence of tampering, hazardous condition, or current diversion as provided under state statutes, Rules and Regulations of the Company, or the Public Service Commission. The Company will not be responsible in any way for any defect in the Customer's wiring or for damage resulting from such defects.

F. ALTERATIONS AND ADDITIONS

1. Service connections, metering, or metering equipment, shall not be removed or relocated except by employees of the Company authorized to do such work.
2. When the Company connects a Customer's installation to its supply lines, arrangements are made for meters, transformers, and other equipment to fit the installation as it is at the time. It is very essential that the customer or contractor give advance notice to the Company of any major addition of equipment which is to be connected to the wiring system.

G. CUSTOMER'S RESPONSIBILITIES

1. The Company shall have the right to enter the premises of the Customer at all reasonable hours for the purpose of making such inspection of the Customer's installation as may be necessary for the proper application of the Company's rate schedules and Rules and Regulations; for installing, removing, testing or replacing its apparatus or property; for reading meters; and for the entire removal of the Company's property in the event of termination of service to the Customer for any reason.
2. All property of the Company installed in or upon the Customer's premises used or useful in supplying service is placed there under the Customer's protection without charge to the Company. All reasonable care shall be exercised to prevent loss or damage to such property, ordinary wear and tear expected.
3. The Customer will be held responsible for breaking the seals, tampering or interfering with the Company's meter or meters or other equipment of the Company installed on the customer's premises. Only authorized employees of the Company will be allowed to make any repairs or any adjustments to any meter or other piece of apparatus belonging to the Company, except for repair or replacement of meter sockets that has been authorized by the Company.

H. REFUSAL OR DISCONTINUANCE OF SERVICE BY THE COMPANY

Under the Rules of the Alabama Public Service Commission, the Company may refuse or discontinue service for certain reasons. Several of these reasons are listed below. These rules are available for inspection, upon request of the Company.

1. Nonpayment of bills for electric service.
2. Without notice in the event of a condition on the Customer's premises determined by the Company to be hazardous.
3. Without notice in the event of customer use of equipment in such a manner as to adversely affect the Company's equipment or the Company's service to others.
4. Without notice in the event of tampering with equipment furnished and owned by the Company.
5. Without notice in the event of unauthorized use.
6. For failure of the Customer to permit the Company reasonable access to its equipment for inspection, securing of meter reading, etc.
7. For violation and/or noncompliance with the Company's rules on file with and approved by the Alabama Public Service Commission.
8. For failure of the Customer to fulfill his contractual obligations for service and/or facilities subject to the regulations by the Alabama Public Service Commission.

I. INTERRUPTION AND LIABILITY

1. The Company will endeavor to furnish continuous service but does not guarantee uninterrupted service, and is not liable for any damage which the customer may sustain by reason of the failure or partial failure of the power, or failure of reversal of phases, or variation in service characteristics, whether caused by accident, repairs or other causes; nor is the Company liable for damage that may be incurred by the use of any service wiring, connections, instruments, services or electrical appliances, installed by or for the customer; nor is the Company liable for damage that may be incurred due to the presence of the Company's property on customers premises. In the case the Customer requires three phase service the installation and maintenance of adequate relays with circuit breakers to protect against single phase conditions and phase reversal are advisable and their installation and maintenance is the responsibility of the Customer.
2. Customers utilizing devices which malfunction upon loss of power should consider the installation of an uninterruptible power supply or other appropriate backup power supply to insure continuity of service to the device. The Company will work with the Customer in every way possible if he has very sensitive equipment and will help him find the proper conditioning equipment to fulfill these needs.

SECTION III

SERVICES

A. GENERAL INFORMATION

1. Normally, there will be only one service voltage available at a location, and only one point of delivery for each building.
2. The point of delivery shall be a mutually agreed upon location between the Customer and Company.
3. All service entrance facilities, including meter sockets, shall be located in an exposed or accessible area.
4. Where conduit or metallic tubing is used, fittings with removable covers should be avoided in the service entrance run if possible. If such fittings cannot be avoided, they shall not be concealed. Overhead service entrance cables and conduits between the weatherhead and the meter socket shall not be concealed.
5. Where a group of customers are served from a service raceway, the covers to the raceway and/or pull boxes must be provided with a means of sealing by the Company.
6. Wires carrying metered energy are not to be located in the same raceway, troughs, boxes or conduit with wires carrying unmetered energy.
7. Grounding
 - A. All services shall have a grounded neutral.
 - B. Grounds shall be established and maintained as required by the National Electric Code and local authority.
8. Conductor Marking
 - A. All neutral conductors shall be clearly marked with a white marker at the point of delivery and at the meter location.
 - B. The power leg (high leg) of each 120/240 volt, three phase, four wire service shall be clearly marked orange, or by other effective means, at the point of delivery and at the meter location in accordance with the NEC or local requirements.

B. TEMPORARY SERVICE

1. If temporary service is desired, the Customer shall make arrangements **on-line or call (888) 430-5787**, well in advance of the required service date. Installations requiring special service, meter, or other work for construction purposes, exhibits of short duration, etc., will be made at the expense of the Customer.
2. Temporary installation of service entrance, other wiring, and meters shall be made and inspected in the same manner as permanent installations.
3. Temporary service for construction purposes may be overhead or underground depending on available service. Arrangements for temporary construction service are shown on Plates C-02 through C-04.
4. The Customer's permanent service panel shall not be connected to the temporary construction service.
5. All temporary poles or underground pedestals shall have a driven ground rod.

C. OVERHEAD SERVICES

1. It is the Customer's responsibility to provide a suitable support for attachment of the service drop conductors. A through eyebolt or a service mast of rigid steel conduit (2" minimum) must be installed for the attachment of the service drop. See Plates C-05 through C-06 for service attachment details.
2. A minimum of two feet of service entrance wire shall be left projecting from the weather head for connection to the service drop. This will allow for sufficient space for the Company to make connections to the Customer's wiring and provide a drip loop per the National Electrical Code.
3. Unless otherwise required by local authorities, the point of attachment of the service drop conductors shall be located by the Customer so as to allow the minimum clearances required in the National Electrical Code. The minimum clearance includes the sag of the service drop conductors.

D. UNDERGROUND SERVICES

1. General
 - a. Underground service is available based on the Company's current specifications. The Customer should contact the Company for the applicability of the underground service policies and possible charges involved before plans are made for underground service.
 - b. In certain areas where the Company has underground distribution, underground service must be used, and overhead service will not be available to the Customer.
 - c. The Customer shall be responsible for any cost incurred by the Company as a result of relocation or repair of Company facilities necessitated by grade changes.
2. Commercial – Industrial Services
 - a. All commercial and industrial underground services will be installed under the terms of the Company's specifications.
 - b. Normal service voltages are 120/240 volt, single phase, three wire; 120/208 volt, three phase, four wire, and 277/480 volt, three phase, four wire. Service voltage of 120/240 volt three phase, four wire, will not normally be available with underground service. It is important that the customer contact the Company to determine the voltage that is available at a desired service location before construction is started.
 - c. The designated point of delivery may be in a meter socket located on the building, in a distribution box, or in a pad mount transformer. When the point of delivery is in a distribution box or transformer, the customer shall leave a minimum of eight feet of the service entrance conductors in position for connection by the Company, unless a shorter length is approved for a specific location.
2. Underground Service from Overhead Facilities
 - a. When requested by a Customer, the Company will install, own, and maintain an underground service from its overhead facilities to the Customer's point of delivery. The Customer shall install a meter socket, provided by the Company, and suitable service entrance facilities, provided by the Customer, at the point of delivery in accordance with the Company's specifications. Prior to such installation, the Customer and the Company will enter into an agreement outlining the terms and conditions of the installation, and the Customer will be required to pay the Company in advance the estimated difference in cost between the underground service and the overhead facilities the Company would otherwise have installed.
 - b. When the Company has previously provided an overhead service to the Customer's point of delivery, the Customer will be required to pay the differential cost of the requested underground service plus the current cost of the existing overhead service facilities.

SECTION IV

METERING INSTALLATIONS

A. GENERAL REQUIREMENTS

1. The Company shall provide and connect all meters, instrument transformers, and meter control wiring necessary to complete the meter installation.
2. The Company shall provide and the customer shall install the necessary meter socket(s) described below:

Generally, the following meter sockets shall be used according to service entrance size:

<u>Service Entrance</u>	<u>Meter Socket/Equipment</u>
200 amps or less	200 amp socket with lever bypass
400 amps or less	320 amp socket with lever bypass
600 amps or less	Transocket
Over 600 amps	Instrument Transformers & Transformer rated socket

Note 1: Varying customer circumstances often create needs for metering equipment different from that shown above. Therefore, a qualified employee of Alabama Power Company shall determine the proper metering equipment to use.

3. On installations involving more than one meter, the following procedures shall apply.
 - a. Where more than one set of line side conductors from single or ganged meter sockets terminate in a trough in which the Company terminates from an underground service, the customer shall make the necessary connections in the trough to allow the Company to terminate into one set of conductors or bus. The trough shall be large enough to provide adequate working space and accommodate the customer's and the Company's conductors and connectors.
 - b. It is necessary for identification purposes that whenever several meters are grouped, all sockets and entrance equipment be plainly and permanently marked to designate the apartment or office served. The marking should be stenciled in black painted numbers or letters at least 1 inch in height.
4. Not more than one service conductor shall be installed under a single terminal in any meter socket. All conductor strand must fit into the terminal. Conductor strands shall not be cut or folded back in an effort to fit conductors into terminals.
5. Proper clearance for the Company's conductors must be left inside meter cabinets by the customer. The left side and top of the cabinets for underground service shall be for the use of the Company only. Space will not permit the customer's conductors to cross over the Company's.
6. Where the electrical inspector has approved the rebar in the concrete footing as the grounding electrode, a ground rod is not required. A minimum #6 copper ground conductor must connect the rebar to the neutral bar in the meter socket or other inspector approved point.
7. The meter socket must not be drilled or damaged during installation of the intersystem bonding termination device required by Article 250.94 of the NEC for electrical bonding of cable, phone, and other services. The device must not interfere with the opening of the meter enclosure. The building owner is responsible for all damage to the meter socket caused by the installation of this device.

B. METER LOCATION

1. The location of meters is an important consideration to both the Company and the Customer. It is very important that a mutually agreed upon meter location be found that will be most suitable to both parties.
2. Plates C-07 through C-14 in the back of this booklet show typical meter installations. In unusual cases, the Company shall be consulted.
3. Meters shall be located on the building in a place where they will be protected from mechanical damage and are not obstructed by shrubs, bushes or plants that would interfere with the reading or testing of the meter. The Customer shall be responsible for providing this protection.
4. Meter sockets and enclosures shall be securely mounted in a plumb and level position on a solid wall or structure. When mounted on masonry walls or structures, meter sockets and enclosures shall be secured with screws set in anchors or with toggle bolts.
5. The center of the meter shall not be more than five feet or less than four feet from the ground (final grade) or floor.
6. Commercial metering will normally be installed outdoors.
7. Where commercial meters are installed inside, they will normally be located on the first floor in a clean, dry, lighted and safe place, easily accessible at all times for reading and testing. Meters shall not be located in rest rooms, dressing rooms, bedrooms, kitchens, ventilating or elevator shafts, boiler rooms, laundry rooms, hallway, etc. Meters shall not be installed near belts or other moving machinery which might endanger those doing work about the meter.
8. A SPACE FREE OF OBSTRUCTIONS, AT LEAST 60 INCHES IN DEPTH, 30 INCHES IN WIDTH AND 7 FEET HIGH SHALL BE MAINTAINED IN FRONT OF ALL METER SOCKETS FOR READING, TESTING AND MAINTENANCE; WHERE MULTIPLE METER SOCKETS ARE INSTALLED, THE WIDTH OF THIS SPACE MUST BE THE GREATER OF 30 INCHES OR THE TOTAL WIDTH OF THE METER SOCKETS.
9. Multiple meter installations should, whenever possible, be outside. However, they may be grouped together in a meter room furnished by the customer for that purpose provided the following requirements are met.
 - a. The Company shall have access to the room at all times for reading, testing, and servicing the equipment.
 - b. Meter rooms may be provided on various floors and mutually agreeable centralized location, at the option of the Company.
 - c. Adequate space, lighting, and access shall be provided as defined in consultation with the Company as the facilities are planned.
10. When meters must be located in areas that are normally locked, the customer must make arrangements such that the Company shall have access to the meters at all times. Further information may be obtained at any local business office.
11. Meters shall not be installed on structures subject to vibration.
12. A minimum horizontal clearance of 3 feet shall be maintained between a meter socket and any gas meter or gas regulator vent.

C. INSTRUMENT TRANSFORMER INSTALLATIONS

1. Instrument transformer rated metering utilizing current transformers (CTs) will be utilized as shown in the previous section IV A. (2).
2. Potential transformers (PTs) will only be used when the service voltage exceeds 480 volts.
3. It is very important to both the Company and the customer that the instructions and construction details, shown in this book, be followed closely on all current transformer installations.
4. The facilities necessary for transformer installations shall be provided and installed as described below:
 - a. The customer shall provide and install all inter-connecting metallic or schedule 40 conduits with a bonding conductor for meter cable between the current transformer enclosure and the meter enclosure. All such conduit shall be a minimum of 1.25 inches in diameter and a maximum of 45 feet in length unless otherwise approved by the engineering department. The customer is to provide a pull string in the conduit.
 - b. The Company shall provide and install the instrument transformers. Where required, the customer shall install the instrument transformer enclosure provided by the Company.
 - c. The Company will provide and install the instrument transformer secondary wiring and meters.
5. Instrument transformer installations are usually made by one of five means, each of which requires coordination between the customer and the Company.
 - a. Indoor/outdoor current transformer enclosure installations are usually used when the customer receives underground service.
 - b. Instrument transformer installations in transformer vaults and pad mounted transformers are applicable only where the vault or transformer provides service for a single customer at a single rate. In these cases, the following requirements apply:
 - (1) Meters shall not be located inside the transformer vault.
 - (2) Meter sockets or other enclosures will not be installed on pad mounted transformers. If it is necessary to have a permanent meter at the pad mounted transformer location, a treated **for ground contact** 6" x 6" timber or six inch galvanized channel iron can be used to attach the meter socket. Refer to Plate **C-16**.
 - (3) A 1.25 inch metallic or schedule 40 conduit with a bonding conductor shall be extended by the customer from the instrument transformer location to the approved meter location for termination in the meter enclosure. The customer shall provide a pull string in the conduit.
 - (4) Necessary meter wiring will be installed and connected by the Company.

SECTION V

EQUIPMENT VAULTS

A. GENERAL REQUIREMENTS

1. It may be necessary or convenient to install Company owned transformers and/or related equipment in a vault inside a customers building. In such cases the customer shall consult with the Company before plans are made concerning the vault.
2. The vault shall be constructed in compliance with Company requirements, the National Electrical Code, and such local requirements as may be in force.
3. The vault shall not contain any customer owned equipment or building services facilities such as: secondary fuses, switches, meters, load control equipment; gas, oil, steam, or water pipes; or ventilation ducts other than those required by the Company.
4. The vault and its contents shall be under the control of the Company, and shall have provisions for locking and security sealing by the Company. Unauthorized persons shall not be permitted to enter the vaults.

B. CUSTOMER RESPONSIBILITIES

1. The customer shall provide and own the following facilities for use by the Company:
 - a. Equipment vault sized in accordance with Company requirements.
 - b. All facilities required to provide natural or forced ventilation determined necessary by the Company.
 - c. All conduit within the building for the Company's facilities, including primary and/or secondary conductors. Such conduit shall extend to a point designated by the Company three feet from the outside building wall.
 - d. Access means including elevators, where applicable, such that transformers and equipment can be rolled from the street or sidewalk directly to and from the vault.
2. The customer shall also provide properly executed easements for all facilities installed on the customers property.

C. COMPANY RESPONSIBILITIES

1. The Company will determine the physical requirements of each vault, including minimum size, ventilation, lighting and conduits. The Company will endeavor to work closely with the customer so that the needs of the Company and the desires of the customer will be considered in the design and construction of the vault.
2. The Company shall provide and own the following:
 - a. Transformers and/or additional necessary equipment.
 - b. Primary and/or secondary cable(s) and related connections.
 - c. Connections to customer owned service cable or bus.

SECTION VI

CUSTOMER UTILIZATION EQUIPMENT

A. GENERAL

1. The Company builds and maintains adequate lines to supply proper service to all customer's using normal equipment. However, since equipment installed by one customer may substantially affect the adequacy and continuity of service to other customer's and because the misuse of some equipment might constitute a fire hazard or endanger life, the Company has established regulations covering the more common installations of utilization equipment.
2. The Company specifies only such requirements as are necessary to safeguard both the customer and the Company with a minimum of interruption and disturbance. The customer should consult the Company for additional details on special equipment which may not be covered in this booklet.
3. Available fault current must be taken into consideration when specifying service entrance equipment. It is important that the customer contact the nearest Engineering office for the value of maximum available fault current.
4. PROTECTION OF EQUIPMENT AGAINST UNDER VOLTAGE, OVER VOLTAGE, VOLTAGE UNBALANCE, OVER CURRENT, PHASE FAILURE, PHASE REVERSAL AND SHORT CIRCUIT IS THE RESPONSIBILITY OF THE CUSTOMER.
5. To protect the property of the customer and the Company, the customer should not overload or over fuse the building's service or branch circuits.

B. MOTORS

1. Single phase, 115 volt motors having a locked rotor current less than 40 amps shall be permitted to be started at line voltage.
2. Single phase, 230 volt motors having a locked rotor current less than 100 amps shall be permitted to be started at line voltage.
3. Single phase motors having locked rotor currents exceeding the limits in Paragraphs 1 and 2 above shall not be started at line voltage without special permission.
4. All single phase motors should be connected for 240 volts, whenever it is practical to do so, in order to minimize voltage drop in the customer's wiring system and the supply system.
5. The horsepower capacity of polyphase motors which may be connected to the Company's line depends on the type of motors to be installed, the capacity of the Company's distribution system, the customer's service entrance wiring and other wiring to the points at which the motors are to be connected, the number of times the motor is to be started and other factors.
6. Because allowable starting currents vary at different locations, a qualified employee in the local District Engineering Department should be consulted before connecting polyphase motors to the Company's distribution system.
7. Where it is not permissible to connect motors for across the line starting, it will be necessary for the customer to provide facilities to limit starting currents to values specified by the Company for the locations involved.

C. SPECIAL EQUIPMENT

1. All flashing signs or lights served by the Company shall be provided with the necessary type of switching equipment to eliminate undesirable flicker, and radio or television interference to other customers.
2. Due to the very severe operating characteristics of such equipment as electric welders, furnaces, X-ray machines, and radio and television broadcasting stations, the customer shall apply to the local Engineering office for approval to use such equipment before installation is made.
3. When the operation of any equipment is detrimental to satisfactory operation of the Company's distribution system, the Company may require the installation of special equipment such as lines and transformers at the expense of the customer.
4. Improperly installed generation equipment can create serious hazards for Company personnel working on the distribution system, as well as for other customers connected to the distribution system. The operation of improperly installed generators can also result in damage to customer's wiring, electrical equipment, or the generator itself. In order to safeguard against these hazards, customer owned generators must be installed as follows:
 - a. Standby generators must be installed in compliance with the NEC and local codes, as applicable. They must be properly connected through transfer switches so that they are completely isolated from the Company's distribution system. Power from a standby generator must never be supplied to another premise because of the danger created by back feeding into the distribution system.
 - b. Generators designed to run in parallel with the Company's system require special protective devices. It is essential that the customer consult the Company regarding these protective requirements before installing or attempting to operate parallel generators

SPECIFICATIONS FOR MANUFACTURED HOME AND TEMPORARY SERVICE

CUSTOMER:

1. Pole— **Treated for ground contact** 18 ft., 4 ft. deep, tamped. (16ft pole with conduit option). Crushed stone for stability if needed.

<u>Type Pole</u>	<u>Dimensions</u>
Round	5" Top Diameter
Square	6" x 6"
Rectangular (temporary only)	4" x 6"

2. Maintain pole plumb, replace if rotted.
3. **The service entrance rating is equivalent to the main breaker or fuse ampere rating (when there is one breaker or fuse). Based on this rating, the minimum size conductors are:**

Service Entrance Rating (Amps)	Copper Conductor Size	Aluminum Conductor Size
60 (temporary only)	6	4
100	4	2
150	1	2/0
200	2/0	4/0
400	400	600

The minimum service rating is 100 amperes 3 wire for a one family dwelling.

4. Weatherhead or gooseneck 18" from top of the pole. Leave 18" leads. Cable straps at top, 12 inches from top, 12 in. from meter socket and 30 inch intervals. Fasten with screws.
5. Mount Company meter socket and weatherproof breaker box with galvanized screws, on 2" x 12" x 36" pressure treated board, or 3/4" x 12" x 36" pressure treated plywood. Attach to pole, with meter socket at 4-5 feet, using galvanized lag screws. The board is not required for single phase installations, 200 amp and smaller, with a 6" x 6" square pole, or a 4" x 6" rectangular pole with the equipment installed on the 6" face of the pole.
6. Seal SE cable at meter socket entrance with bushing and sealant.
7. Conduit Option: 2 inch I.D. rigid galvanized or IMC, with weatherhead. Two ft of conduit above pole. No joints above or within 2 feet of top of pole. Install on side of pole opposite service drop. Three metal conduit straps (minimum), one near top, one mid-way and one within a foot of the meter socket. Fasten each strap with two galvanized 1/4" by 2-1/2" lag screws.
8. PVC conduit to the home— gray schedule 40 or schedule 80 if subject to physical damage, buried 18 inches deep. Galvanized— 6 inches deep, if buried. The feeder conductors for manufactured homes must be either a factory installed cord or four insulated conductors, color-coded or field marked for identification.
9. GFCI required on temporary services.
10. Ground rod: 3/4" x 8' galvanized pipe, 1/2" x 8' copper clad rod, or 5/8" x 8' solid galvanized steel rod.
11. Ground wire: #6 copper min. from meter socket to rod, stapled to pole. No splices. Connect with NEC approved clamp.
- 11.1 **The meter socket must not be drilled or damaged during installation of the intersystem bonding termination device required by Article 250.94 of the NEC for electrical bonding of cable, phone and other services. The device must not interfere with the opening of the meter enclosure. The building owner is responsible for all damage to the meter socket caused by the installation of this device.**

COMPANY:

12. Provide meter socket.
13. Specify location of service.
14. Connect the overhead service.

NOTES:

15. Service will not be pulled over a trailer or building.
16. All aspects of meter pole wiring must comply with NEC.
17. **For wireless device antenna attachments to customer service poles, refer to Plate C-02-3 for additional notes.**

Date 01-13-17	DESCRIPTION Permanent Residential Service	 Alabama Power	A- C-02-1
	Installation To A Mobile Home Or Temporary		
	Construction Installation		

SERVICE POLE AND CLEARANCE REQUIREMENTS

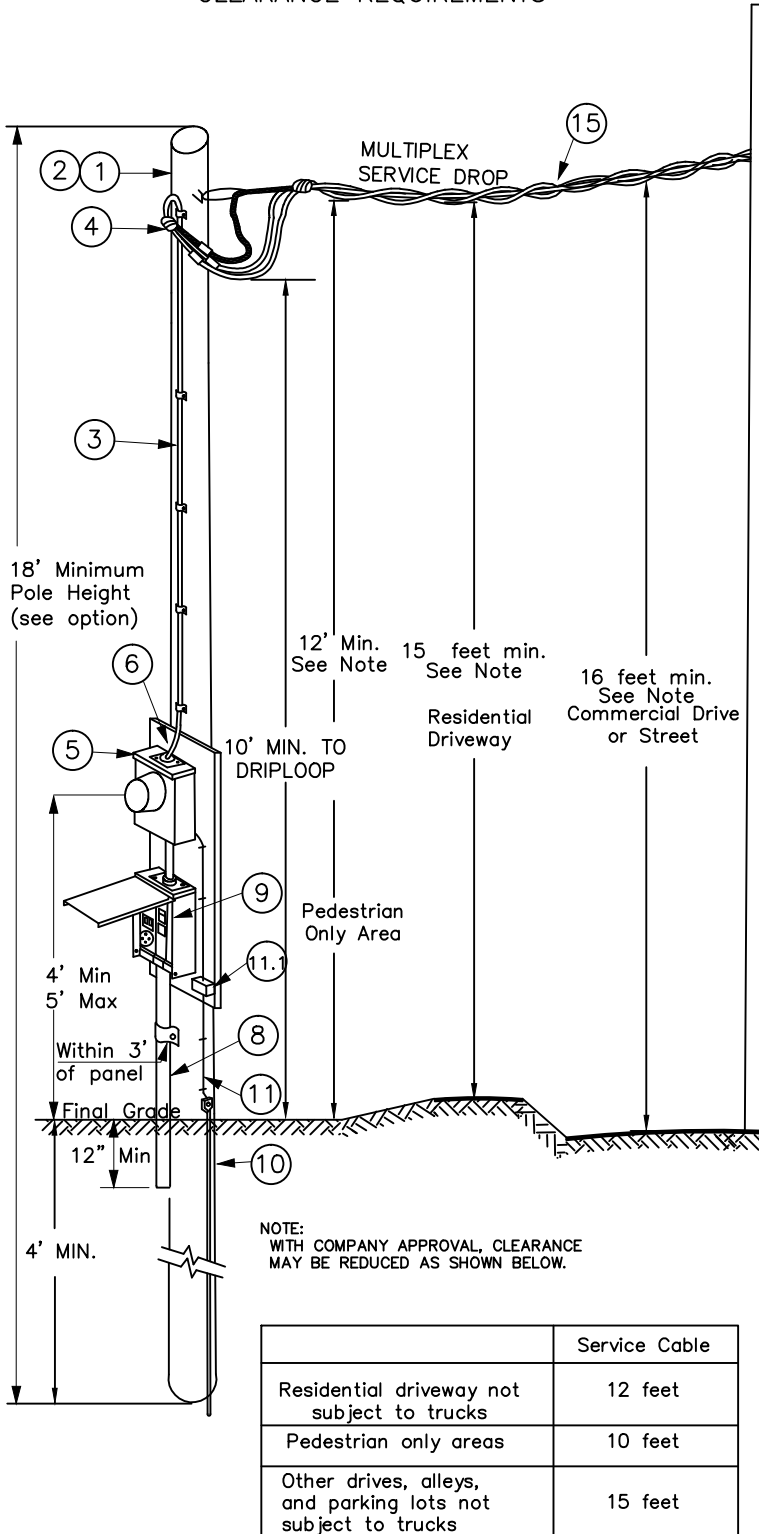

OPTIONAL SERVICE POLE WITH GALVANIZED CONDUIT MAST

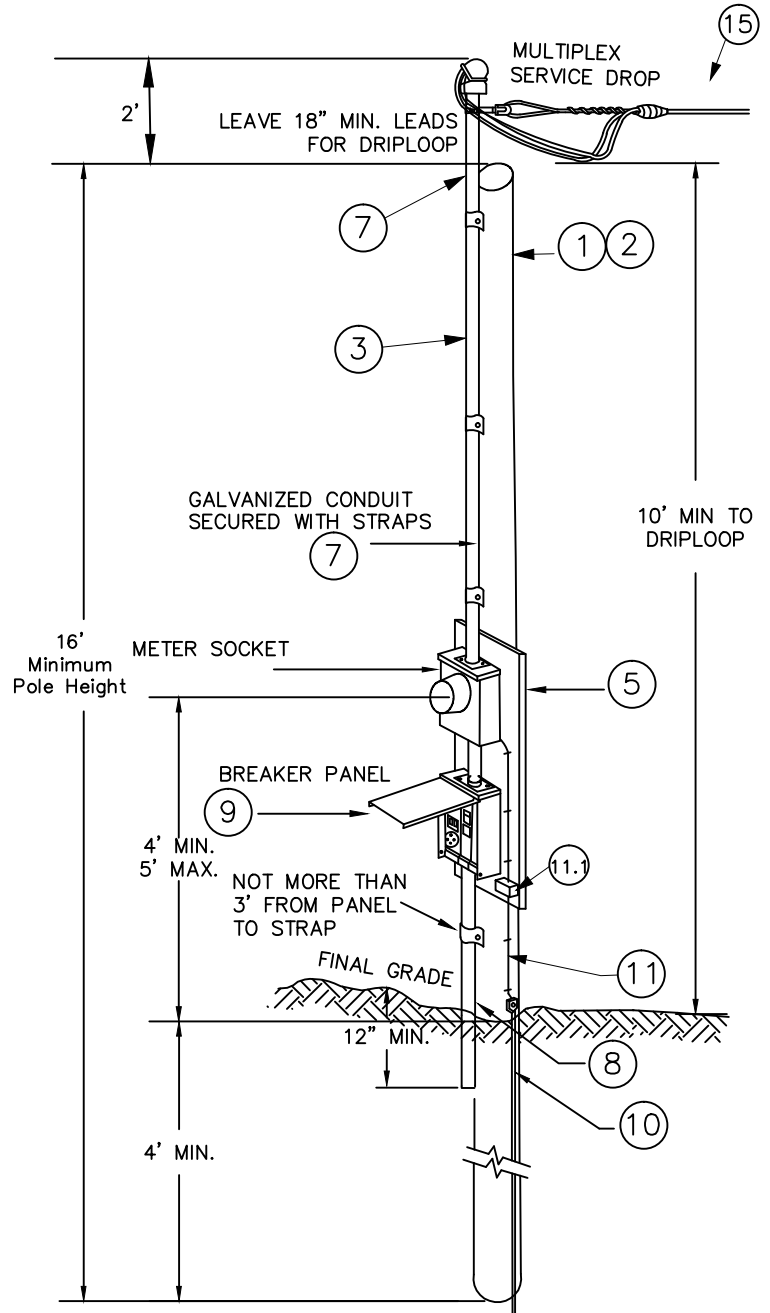

All Clearance Requirements for the service drop are the Same as Shown on the drawing to the left.

Date
03-09-17

DESCRIPTION Permanent Residential Service
Installation To A Mobile Home Or Temporary
Construction Installation 120/240 volt only



Alabama Power

A- C-02-2

CUSTOMER:

1. An overcurrent protective device including a disconnect switch shall be supplied and installed by the owner and shall be located on the load side of the meter. The disconnect switch shall isolate the transmitter from all power sources, including any uninterruptible power supplies or other battery back-up systems. When the disconnect switch is in the "open" position, it shall not be possible for the transmitter to be re-energized remotely. The disconnect switch shall be located in the General Population Exposure Area to prevent excessive RF exposure to the person operating the disconnect. Refer to Plate C-02-4 for additional details.
2. The customer equipment including service pole, antenna, and any other associated device or structure, including the RF Occupational Exposure Area, shall be located not less than 10 feet in all directions from the closest point of all adjacent electric supply poles and associated pole attachment facilities, including underground electric supply facilities. If the 10' distance is not attainable due to field restraints, contact Corporate Distribution. Refer to Plate C-02-4.5, Diagram "A", for additional details.
3. The owner of any RF emitting service equipment shall ensure that all applicable Codes, Rules, and Laws (including, but not limited to OSHA, FCC, and the NEC) are met before and during any time electric service is supplied. If any installation of RF emitting service equipment is found to not comply with the above specifications, electric service will not be provided (or will be immediately disconnected), until the non-compliance issue is resolved.
4. Flat rate metering (an installation without a meter) is not allowed.
5. Wireless device antenna circuit shall be a dedicated circuit and not wired into other customer circuits.
6. Owner contact information shall be permanently identified and maintained on the wireless device cabinet with a sign denoting the owner's name, address, and emergency phone number.
7. Pole-mounted service entrance cable straps shall be installed at the weatherhead, 12 inches from the weatherhead, 12 inches from the meter socket, and at 30 inch intervals.
8. The service entrance cable shall be sealed at the meter socket entrance with bushing and sealant.
9. Ground rod: 3/4" x 8' galvanized pipe, 1/2" x 8' copper clad rod, or 5/8" x 8' solid galvanized steel rod.
10. Ground wire: #6 CU min. from meter socket to ground rod with no splices. Connect with NEC approved clamp.
11. The meter socket must not be drilled or damaged during installation of an intersystem bonding termination device required by Article 250.94 of the NEC for electrical bonding of cable, phone, and other services.
12. For underground installations, cable pull must be verified for use of offset bends at the customer's pole. Conduit size at the service pole is based on conductor size and meter socket knockout size. Customer provided conduit must be schedule 80 PVC or equivalent for all exposed sections.
13. All aspects of the customer service pole wiring must comply with the NEC.

COMPANY:

1. The Company will provide the meter socket, specify the location of service, and make the service connections.
2. When practical, prior to disconnecting power to the antenna, the Company will provide 24 hours advance notice to the antenna owner.

Date 04-08-19	DESCRIPTION SERVICE TO WIRELESS DEVICE ANTENNA ATTACHMENTS ON CUSTOMER SERVICE POLES (SHEET 1)	 Alabama Power	A- C-02-3
------------------	--	---	-----------

DIAGRAM "A" - OVERHEAD CUSTOMER SERVICE POLE DETAILS (SIDE VIEW)



Note:
With company approval, clearance may be reduced as shown below.

DIAGRAM "B" - UNDERGROUND SERVICE POLE DETAILS (SIDE VIEW)

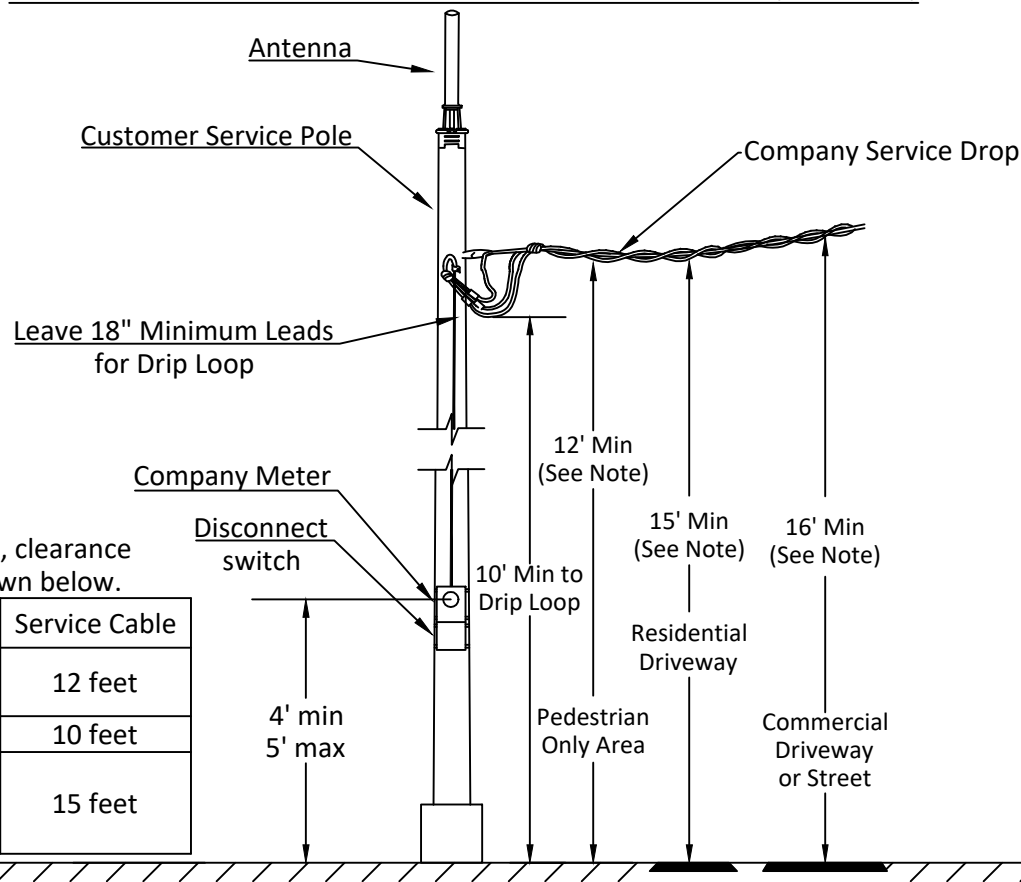
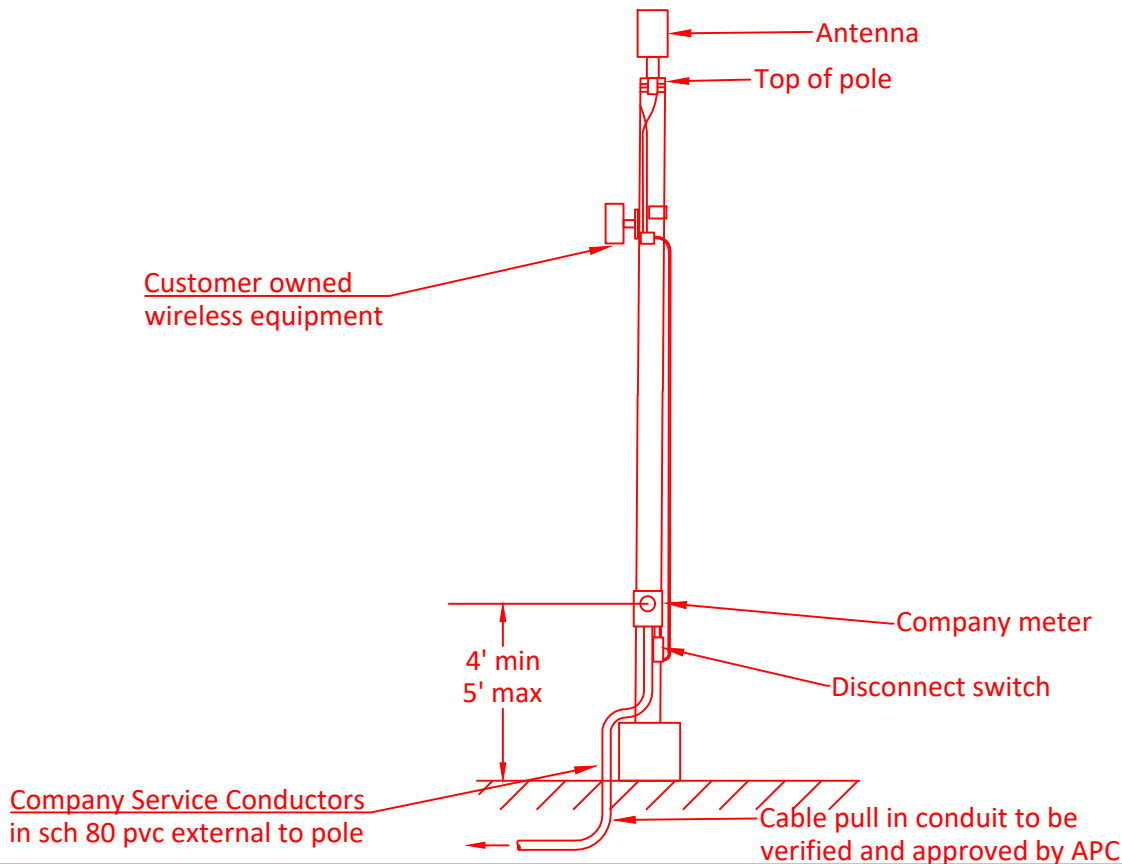

Date
04-08-19

DESCRIPTION SERVICE TO WIRELESS DEVICE ANTENNA ATTACHMENTS ON CUSTOMER SERVICE POLES (SHEET 2)



A- C-02-4

DIAGRAM "A" - RADIO FREQUENCY EXPOSURE AREA (TOP VIEW)

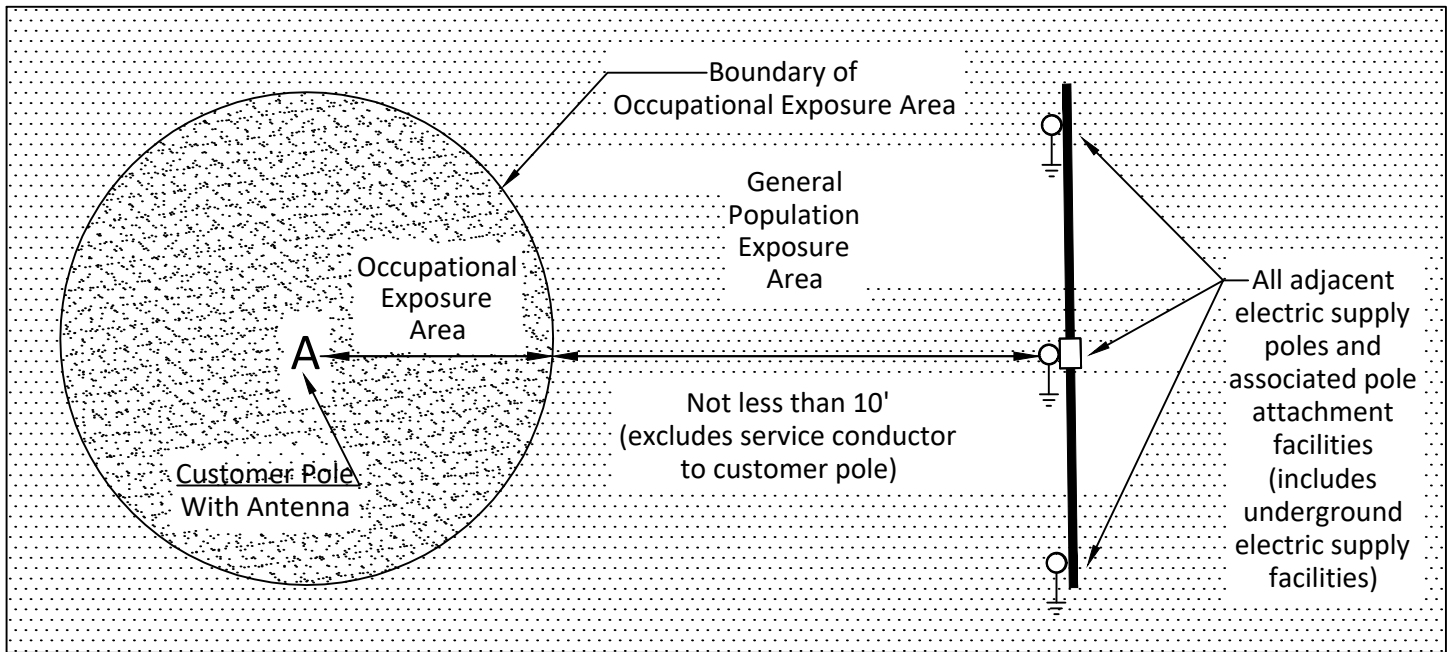



DIAGRAM "B" - METER SOCKET LOCATION NEAR ROADWAY AND SIDEWALK

SIDEWALK OR PARKING AREA



<p>Date 04-08-19</p>	<p>DESCRIPTION SERVICE TO WIRELESS DEVICE ANTENNA ATTACHMENTS ON CUSTOMER SERVICE POLES (SHEET 3)</p>	 Alabama Power	<p>A- C-02-4.5</p>
--------------------------	---	---	--------------------

**UG SERVICES FROM APC POLES TO
TRANOCKET OR 320-A METER SOCKET**

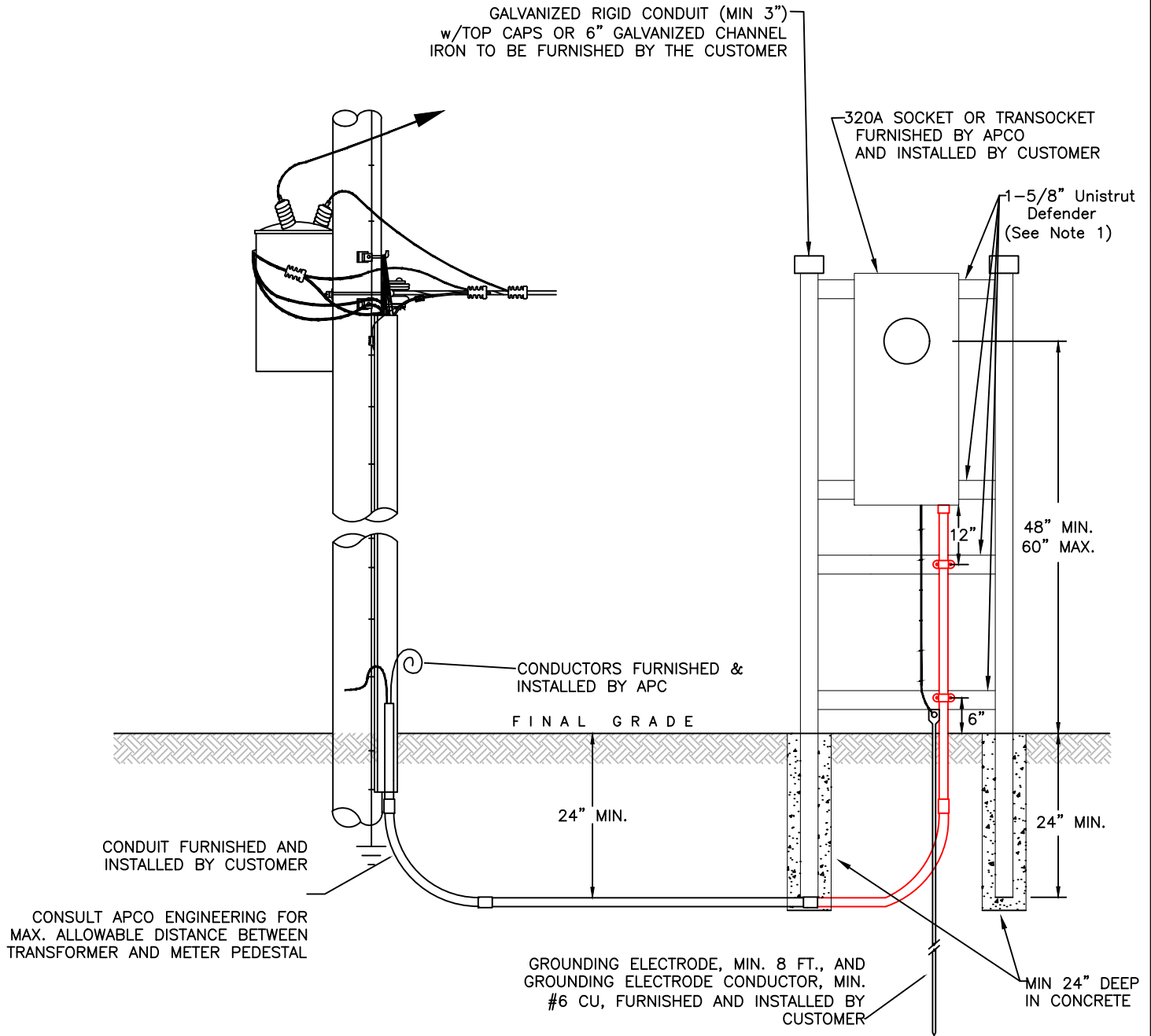

Note 1: Comparable product to Unistrut Defender is acceptable.

SUBJECT _____

DETAIL UG SERVICES FROM APC POLES TO TRANOCKET OR 320A METER SOCKET

Date 12-06-23

SUPERSEDES C-02-5
DATE 08-05-21

SHEET ____ OF ____ SHEETS

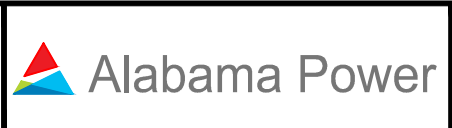

A- C-02-5

CREOSOTED POLE OR TREATED TIMBER, TREATED FOR GROUND CONTACT (4" X 4" MINIMUM SIZE), OR 6" GALVANIZED CHANNEL IRON TO BE FURNISHED AND INSTALLED BY THE CUSTOMER. MINIMUM SETTING DEPTH 24 INCHES.

METER TROUGH, SINGLE PHASE 200 AMPERE, FURNISHED BY ALABAMA POWER AND INSTALLED BY THE CUSTOMER.

CUSTOMER TO SUPPLY AND INSTALL MAIN SWITCH, OVERCURRENT PROTECTION AND WIRING DEVICES IN A WEATHERPROOF ENCLOSURE WITH WEATHERPROOF COVERS. SEE LOCAL AUTHORITIES FOR ANY REQUIREMENTS BEYOND THESE LISTED.

CONDUIT STRAPS SPACED AT A MAXIMUM DISTANCE OF 24 INCHES APART TO BE FURNISHED AND INSTALLED BY THE CUSTOMER.

CONDUIT TO BE 1-1/4 INCH MINIMUM I.D. PVC SCHEDULE 40 OR RIGID GALVANIZED. CONDUIT, OR LIQUIDTIGHT FLEXIBLE NON METALLIC CONDUIT, BUSHING, TYPE LB ACCESS FITTING AND CONDUCTOR TO BE FURNISHED AND INSTALLED BY THE CUSTOMER.

ACCESS HOLE ADAPTER PLATE TO BE FURNISHED BY THE CUSTOMER AND INSTALLED BY ALABAMA POWER.

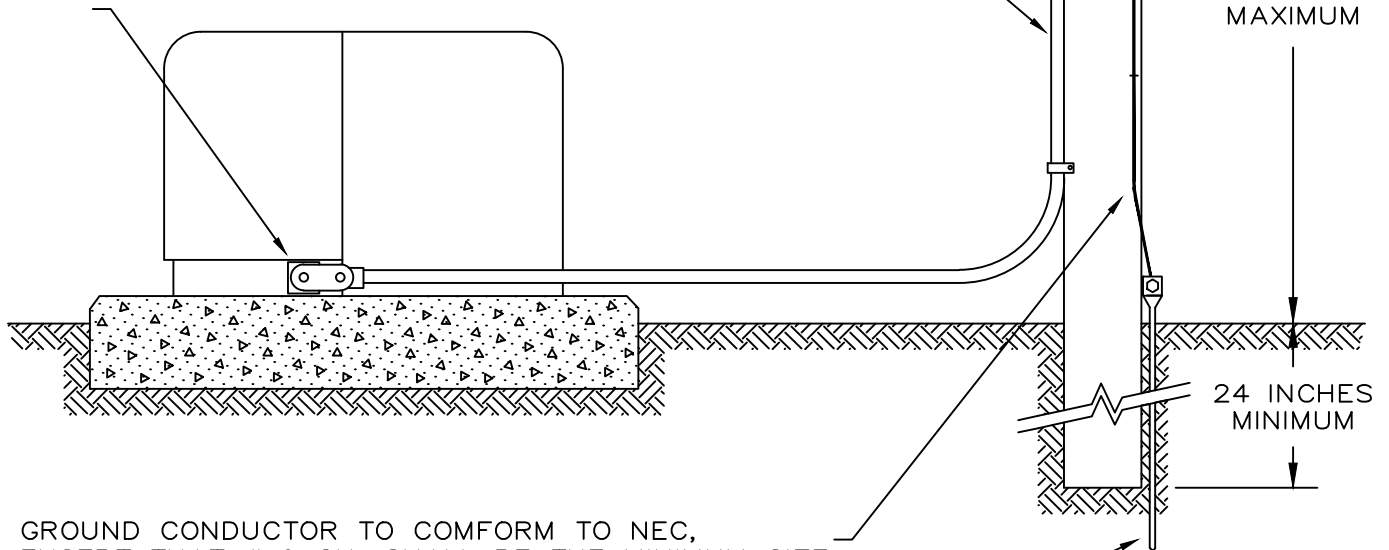

GROUND CONDUCTOR TO CONFORM TO NEC, EXCEPT THAT # 6 CU. SHALL BE THE MINIMUM SIZE TO BE FURNISHED AND INSTALLED BY THE CUSTOMER.

GROUND ROD TO CONFORM TO NEC, FURNISHED AND INSTALLED BY THE CUSTOMER.

ALABAMA POWER IS TO MAKE THE SERVICE CONNECTION IN PAD-MOUNTED TRANSFORMER.

<p>Date 08-11-16</p>	<p>DESCRIPTION Temporary Service Installation from a Pad-Mounted Transformer with an Access Hole</p>	 Alabama Power	<p>A- C-03-1</p>
--------------------------	--	---	------------------

CREOSOTED POLE OR TREATED TIMBER, TREATED FOR GROUND CONTACT (4" X 4" MINIMUM SIZE), OR 6" GALVANIZED CHANNEL IRON TO BE FURNISHED BY THE CUSTOMER. MINIMUM SETTING DEPTH 24 INCHES.

METER TROUGH, SINGLE PHASE 200 AMPERE, FURNISHED BY ALABAMA POWER AND INSTALLED BY THE CUSTOMER.

CUSTOMER TO SUPPLY AND INSTALL MAIN SWITCH, OVERCURRENT PROTECTION AND WIRING DEVICES IN A WEATHERPROOF ENCLOSURE WITH WEATHERPROOF COVERS. SEE LOCAL AUTHORITIES FOR ANY REQUIREMENTS BEYOND THESE LISTED.

CONDUIT STRAPS SPACED AT A MAXIMUM DISTANCE OF 24 INCHES APART TO BE FURNISHED AND INSTALLED BY THE CUSTOMER.

CONDUIT TO BE 2 INCHES MINIMUM I.D. PVC SCHEDULE 40 OR RIGID GALVANIZED WITH BUSHING TO BE FURNISHED AND INSTALLED BY THE CUSTOMER.

GROUNDING CONDUCTOR TO CONFORM TO NEC 250-66; EXCEPT THAT #6 COPPER SHALL BE THE MINIMUM SIZE TO BE FURNISHED AND INSTALLED BY THE CUSTOMER.

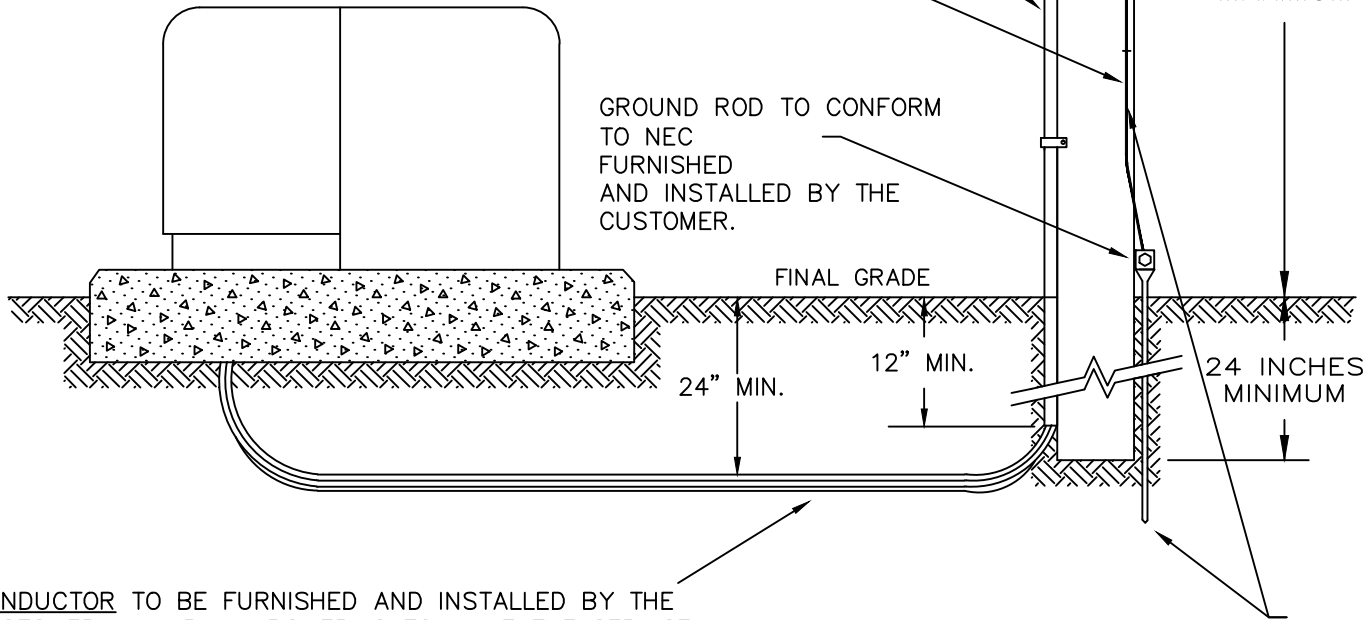

CONDUCTOR TO BE FURNISHED AND INSTALLED BY THE CUSTOMER. ALABAMA POWER IS TO MAKE THE SERVICE CONNECTION IN THE PAD-MOUNTED TRANSFORMER.

CUSTOMER TO FURNISH AND INSTALL THE GROUNDING ELECTRODE AND GROUNDING ELECTRODE CONDUCTOR.

<p>Date 08-11-16</p>	<p>DESCRIPTION Temporary Service Installation from a Pad-Mounted Transformer Without an Access Hole</p>	 Alabama Power	<p>A- C-04-1</p>
--------------------------	---	---	------------------

**UG SERVICES FROM PADMOUNTED TRANSFORMERS
TO TRANSOCKET OR 320-A METER SOCKET**

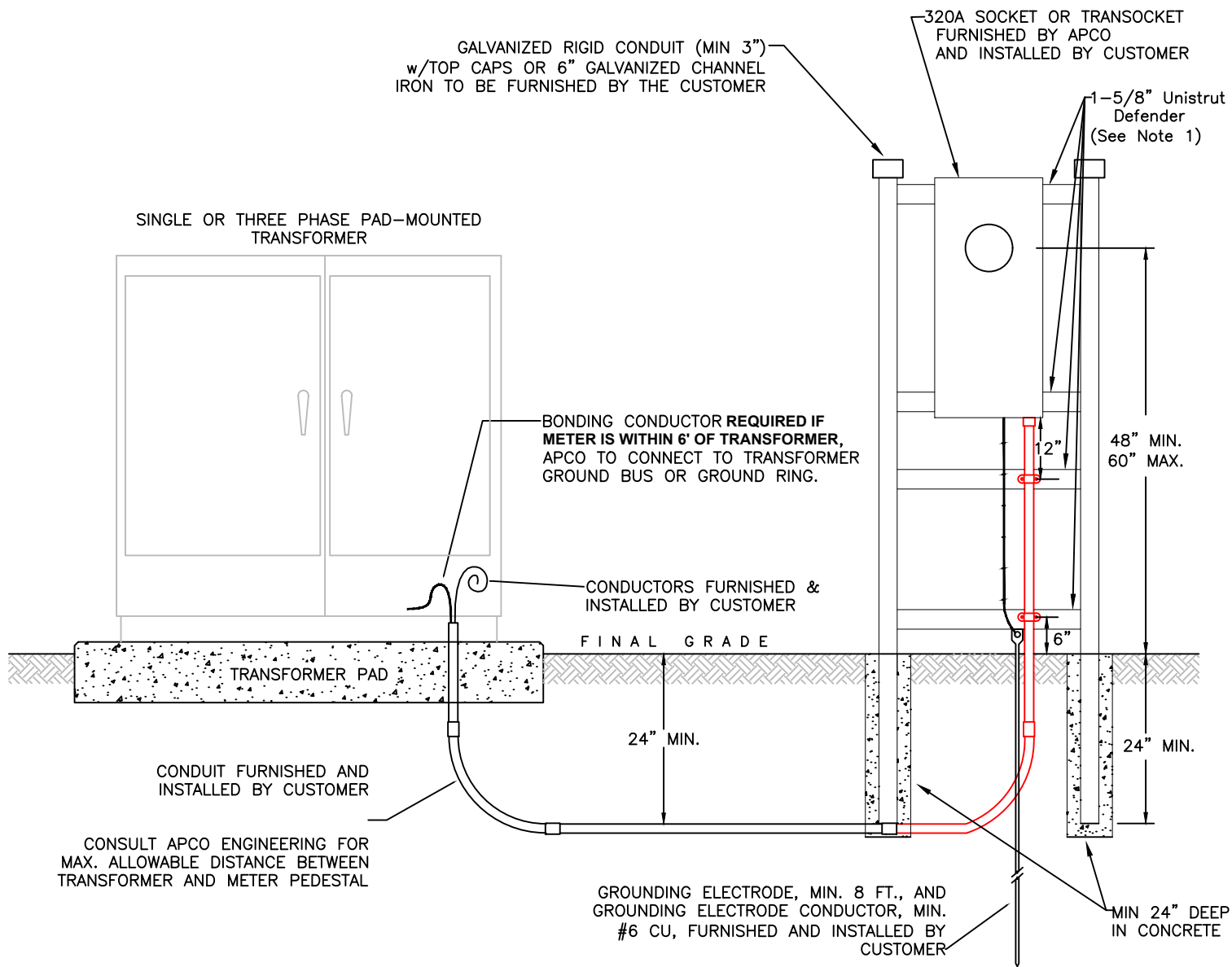

Note 1: Comparable product to Unistrut Defender is acceptable.

SUBJECT _____

DETAIL UG SERVICES FROM A PAD-MOUNT TRANSFORMER TO TRANSOCKET OR 320A METER SOCKET

Date 12-06-23

SUPERSEDES C-04-2
DATE 08-05-21

SHEET ____ OF ____ SHEETS

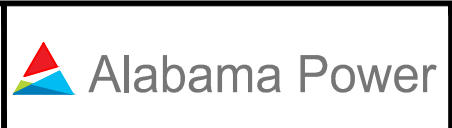

A- C-04-2

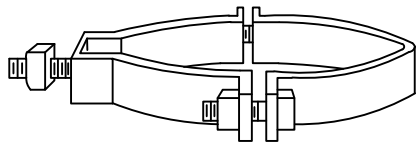

DETAIL A

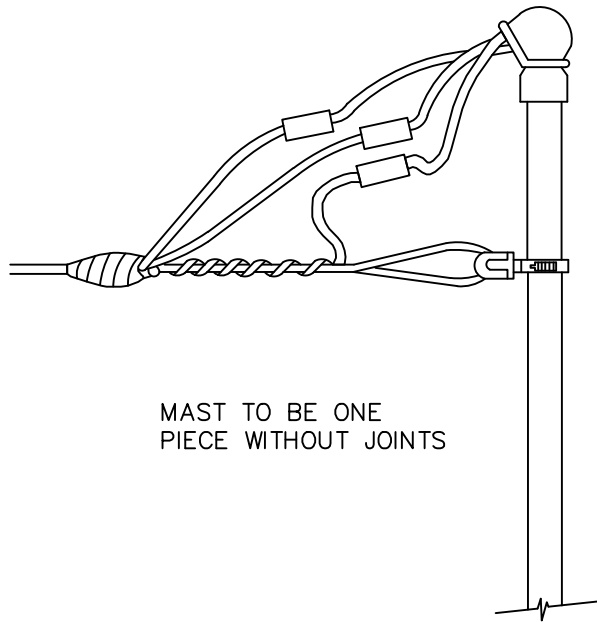

MAST TO BE ONE
PIECE WITHOUT JOINTS

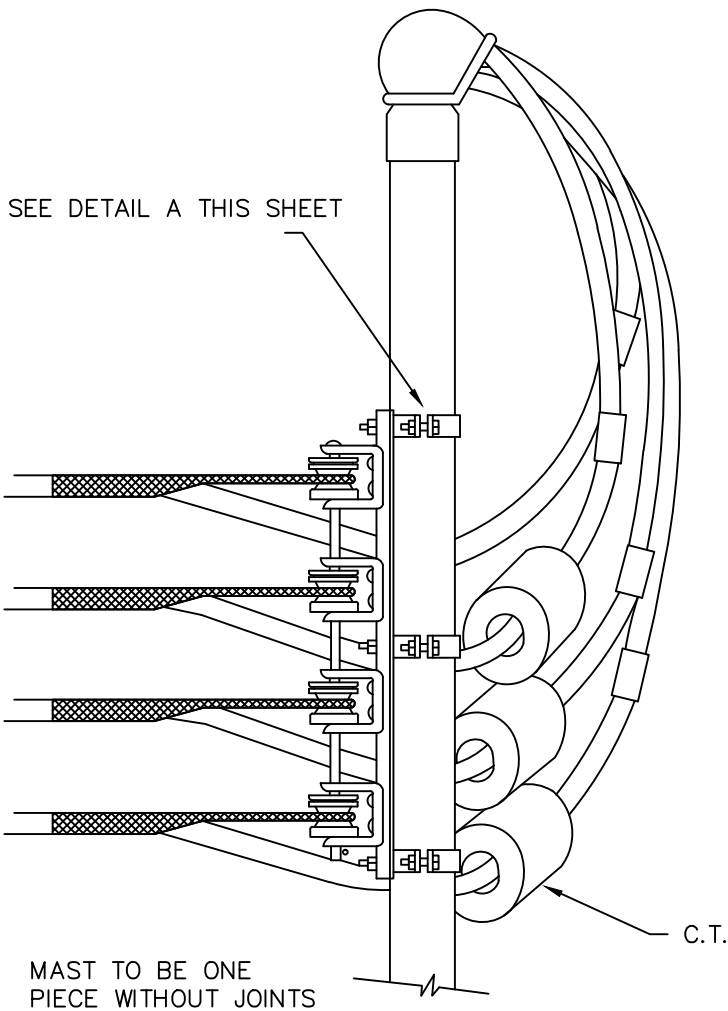

NOTE: (FOR 4/0 ALUMINUM & LARGER APC_o SERVICE)

ATTACHMENT TO SERVICE MAST TO BE USED ONLY WHERE IT IS IMPOSSIBLE TO ATTACH WIRE - HOLDERS TO BUILDING WALL AND MAINTAIN PROPER CLEARANCE TO GROUND. LONG OVERHEAD SERVICES MAY REQUIRE THE MAST TO BE GUYED BACK TO THE ROOF.

CONDUIT SIZE (INCH)	MAXIMUM TENSION (LBS)
2	800
2-1/2	1200
3-1/2	1600

Date	DESCRIPTION	 Alabama Power	A- C-05-1
12/01/99	Attachments to Service Entrance Masts		

SUGGESTED DEAD END
ARRANGEMENT AT SERVICE ENTRANCE

SUGGESTED METHODS FOR ANCHORING
DEAD END AT BUILDING

CUSTOMERS BUS DUCT OR WEATHERHEAD

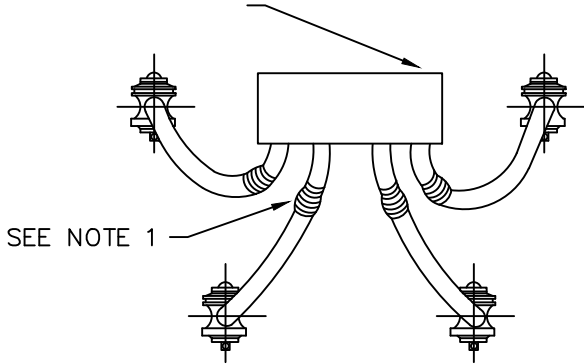

CUSTOMERS BUS DUCT OR WEATHERHEAD

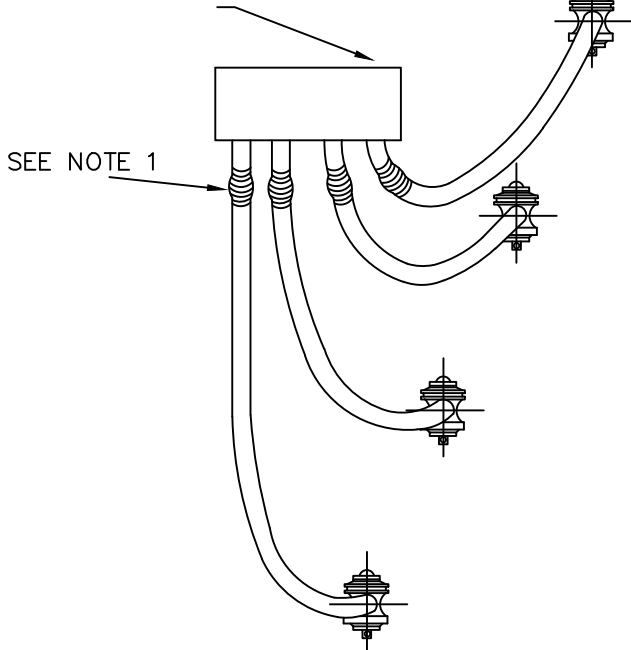

NOTES:

1. WRAP ALL EXPOSED CONDUCTORS AND CONNECTORS AT CUSTOMERS SERVICE ENTRANCE WITH WEATHERPROOF TAPE.
2. DRILL THROUGH MASONRY WALL WITH 3/4" X 12" RAWL DRILL AND INSTALL 2" X 4" WOODEN HEADER ON INSIDE WALL.
3. ATTACH SERVICE TO BUILDING HIGH ENOUGH TO AVOID SERVICE CONTACTING BUILDING AT STEEP ANGLE.

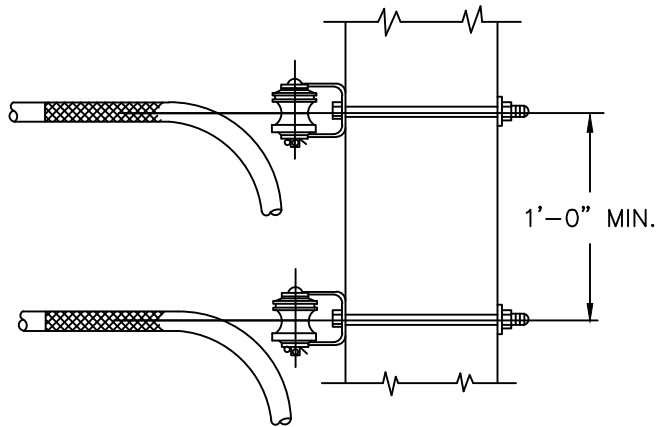

WOOD STRUCTURES

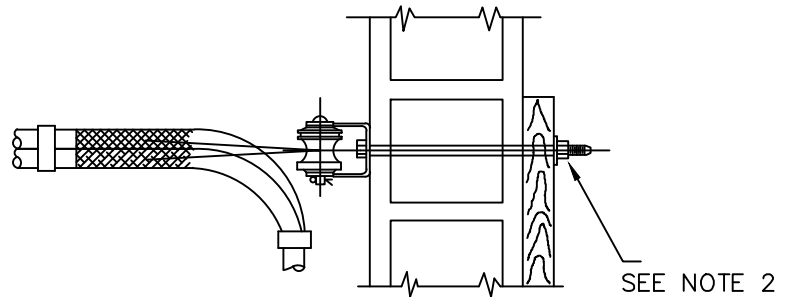

HOLLOW TILE OR
CONCRETE BLOCK

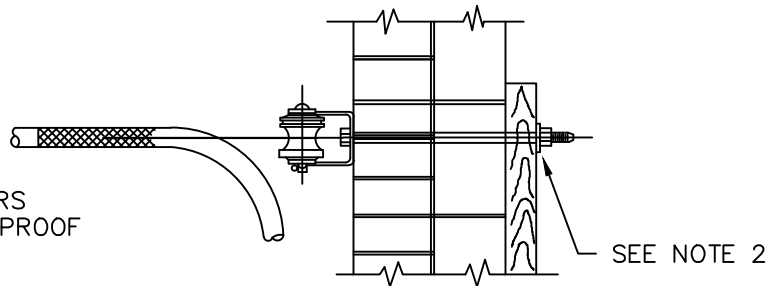

BRICK OR
SOLID CONCRETE

Date
12/01/99

DESCRIPTION Attachments to Buildings with
Large Conductors



A- C-06-1

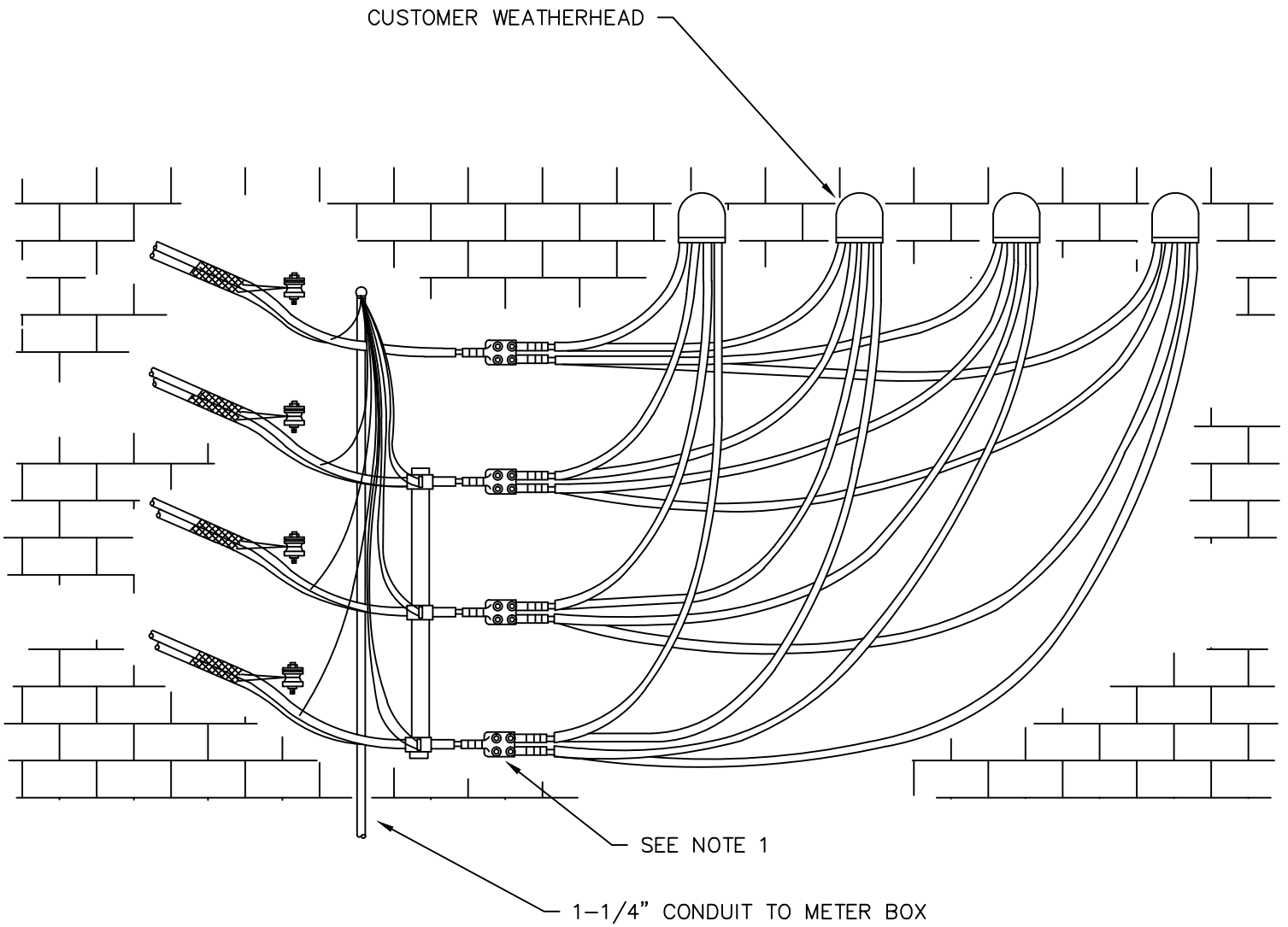

NOTES:

1. APCo IS TO WRAP ALL EXPOSED CONDUCTORS AND CLAMPS WITH WEATHERPROOF TAPE.

Date 12/01/99	DESCRIPTION Attachments to Buildings with Large Conductors	 Alabama Power	A- C-06-2
------------------	---	---	-----------

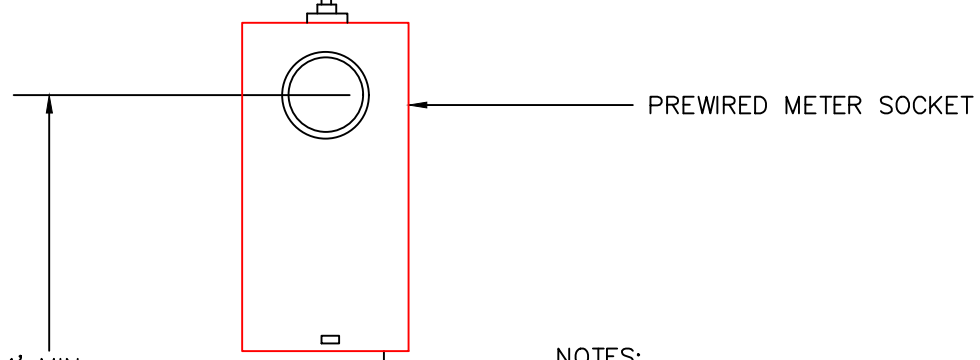
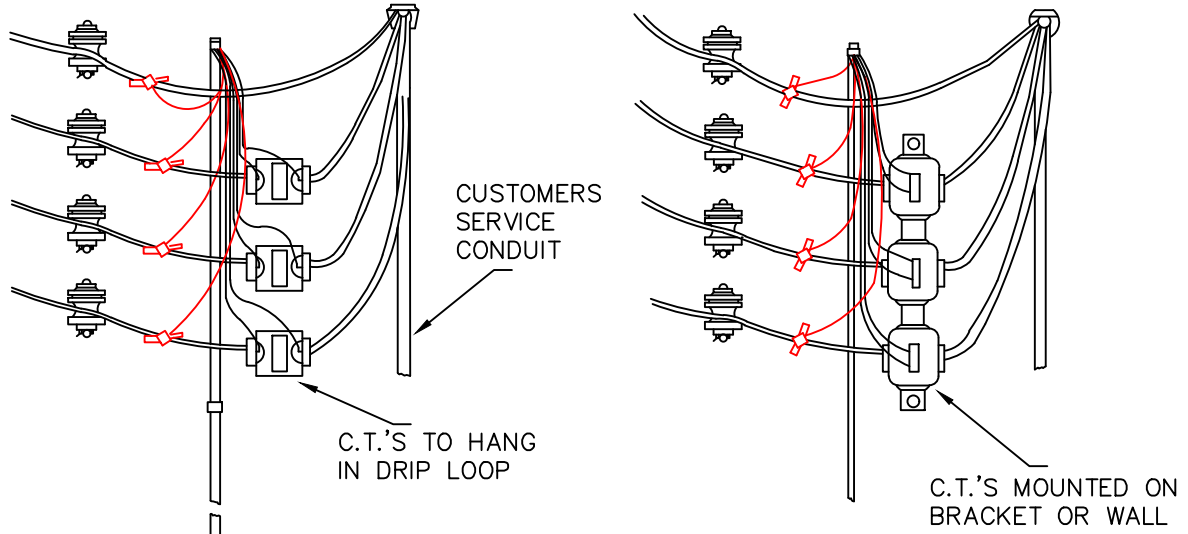

4' MIN.
5' MAX.
ON OUTDOOR INSTALLATION

#6 COPPER GROUND WIRE BONDED TO THE BUILDING GROUNDING ELECTRODE SYSTEM



NOTES:

1. THE COMPANY WILL PROVIDE THE INSTRUMENT TRANSFORMERS WITH BRACKETS, THE METER CABLE, THE METER SOCKET AND MAKE CONNECTIONS TO THE INSTRUMENT TRANSFORMERS AND SOCKET. THE CUSTOMER WILL PROVIDE THE CONDUIT AND INSTALL THE INSTRUMENT TRANSFORMERS, CONDUIT AND METER SOCKET.
2. WEATHERHEADS ARE TO EXTEND UP TO THE LEVEL OF THE TOP SERVICE WIRE OF THE TOP OF THE RACK TO PROVIDE NATURAL DRIP LOOPS.

Date 02-21-22	DESCRIPTION Metering – Three Phase, Four Wire, Using 600 Volt Outdoor Through type C.T.'s	 Alabama Power	A- C-07-1
------------------	--	---	-----------

PRE-WIRED METER TROUGH, 1 ϕ , OR 3 ϕ , TO BE FURNISHED BY ALABAMA POWER Co. AND INSTALLED BY THE CUSTOMER

#6 GROUND WIRE FOR GROUNDING THE METER TROUGH AND C.T. CABINET IS TO BE FURNISHED AND INSTALLED BY THE CUSTOMER AND BONDED TO THE BUILDING GROUNDING ELECTRODE SYSTEM PER NEC 250-92.

1-1/4" CONDUIT FOR METER CABLE TO BE FURNISHED AND INSTALLED BY THE CUSTOMER

C.T.'S AND CABINET TO BE FURNISHED BY ALABAMA POWER COMPANY AND INSTALLED BY THE CUSTOMER

PVC SCHEDULE 40 CONDUIT, BUSHING AND HUB FOR SERVICE RISER TO BE FURNISHED AND INSTALLED BY THE CUSTOMER

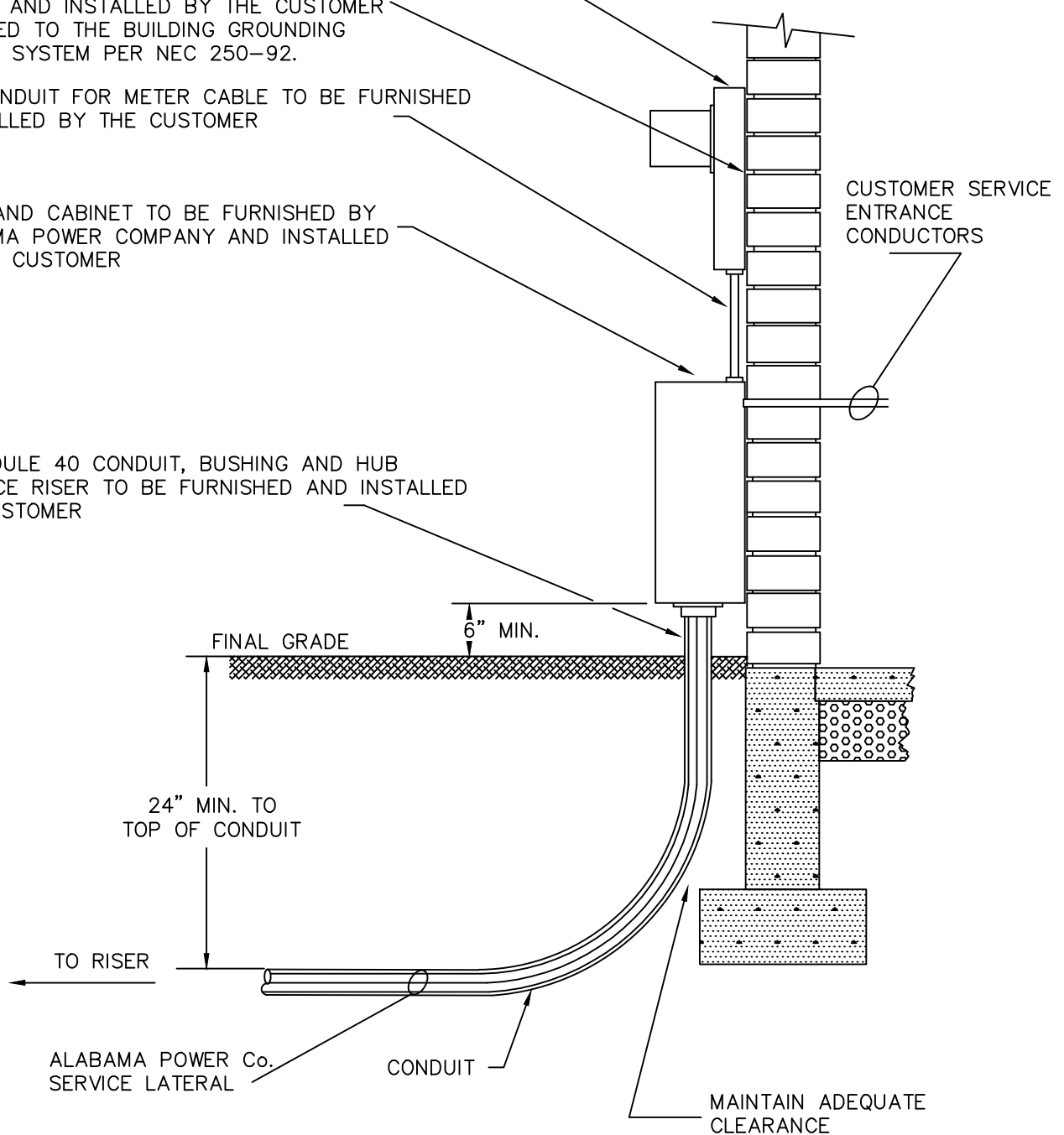

Date
03-09-17

DESCRIPTION Metering - Underground Service
Entrance with Above Grade C.T.'s



Alabama Power

A- C-08-1

DELTA CONNECTED
TRANSFORMER BANK

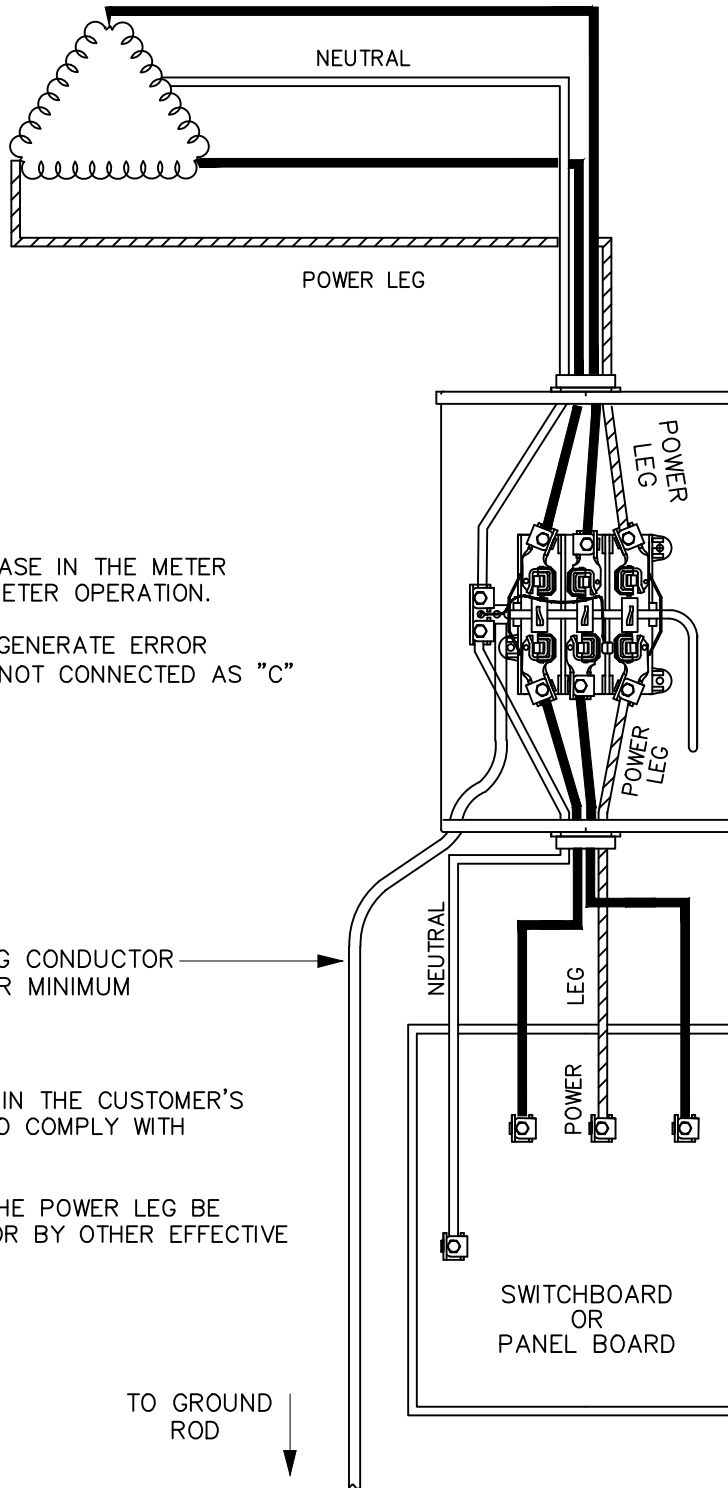

POWER LEG MUST BE "C" PHASE IN THE METER
SOCKET FOR THE CORRECT METER OPERATION.

AN ELECTRONIC METER WILL GENERATE ERROR
MESSAGES IF POWER LEG IS NOT CONNECTED AS "C"
PHASE.

GROUNDING CONDUCTOR
#6 COPPER MINIMUM

POWER LEG MUST BE "B" PHASE IN THE CUSTOMER'S
SWITCHBOARD OR PANELBOARD TO COMPLY WITH
SECTION 408.3(E) OF THE NEC.

THE NEC ALSO REQUIRES THAT THE POWER LEG BE
PERMANENTLY MARKED ORANGE OR BY OTHER EFFECTIVE
MEANS PER SECTION 230.56.

TO GROUND
ROD

Date

02-16-10

DESCRIPTION Power Leg Connections on
Three Phase, Four Wire Delta Connected Systems



Alabama Power

A- C-09-1

Transocket Furnished by APCo and installed by Customer

Line connectors are each dual 600 kcm capacity.

Load connectors are each triple 250 kcm capacity.

Four (4) knockouts, each with 3" and 4" knockouts.

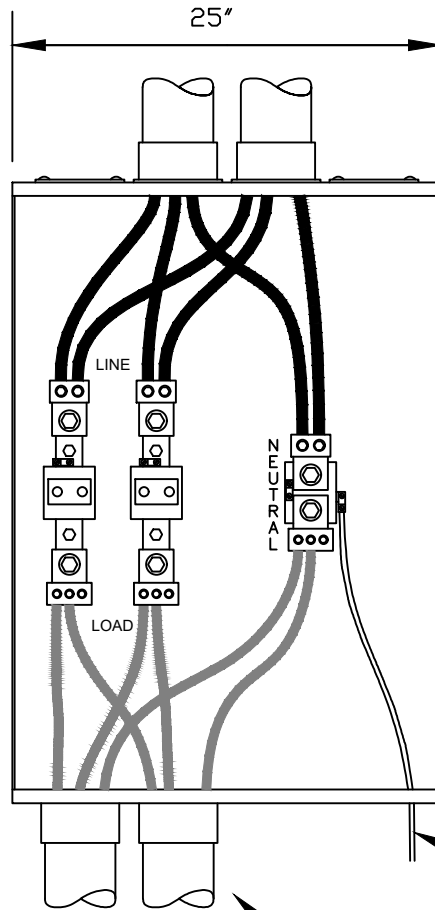

Line side Service Entrance conductors, hubs, conduit, and/or cable furnished and installed by customer

Transocket cover, metering inner panel, and meter wiring omitted for clarity

36"

Grounding electrode conductor, minimum #6 Copper, furnished and installed by customer

Load side conductors, conduit, and hubs furnished and installed by customer

Date
05-25-11

DESCRIPTION Transocket Installation for a Single Phase Overhead Service



Alabama Power

A- C-10-2

Transocket Furnished by APCo and installed by Customer

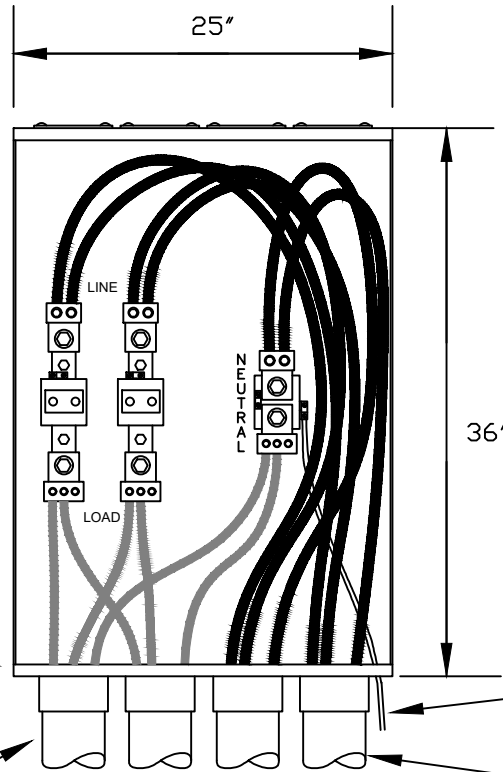

Line connectors are each dual 600 kcm capacity.

Load connectors are each triple 250 kcm capacity.

Four (4) knockouts, each with 3" and 4" knockouts.

Load side conductors, conduit, and adapters furnished and installed by customer

Transocket cover, metering inner panel, and meter wiring omitted for clarity

Grounding electrode conductor, minimum #6 copper, furnished and installed by customer

Line Side:

Pad-Mount: Customer will furnish and install Schedule 40 conduit, adapters and conductors. Schedule 80 building riser conduit required if subject to physical damage.

Pole: Customer will furnish and install Schedule 40 conduit, and adapters. Schedule 80 building riser conduit required if subject to physical damage. Company will furnish and install conductors.

Date
05-25-11

DESCRIPTION Transocket Installation for a Single Phase Underground Service



A- C-10-3

Transocket Furnished by APCo and installed by Customer

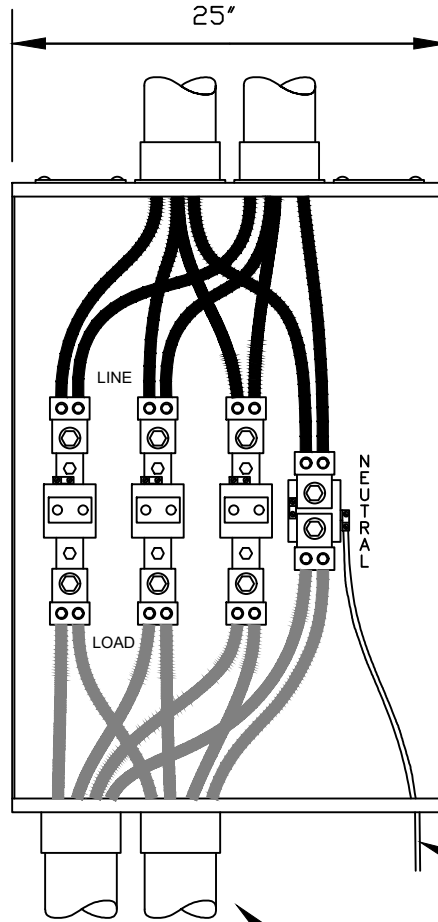

Line side Service Entrance conductors, hubs, conduit, and/or cable furnished and installed by customer

Transocket cover, metering inner panel, and meter wiring omitted for clarity

Line connectors are each dual 600 kcm capacity.

Load connectors are each dual 600 kcm capacity.

Four (4) knockouts, each with 3" and 4" knockouts.

36"

Grounding electrode conductor, minimum #6 Copper, furnished and installed by customer

Load side conductors, conduit, and hubs furnished and installed by customer

Date
09-26-16

DESCRIPTION Transocket Installation for a Three Phase Overhead Service

 Alabama Power

A- C-10-4

Transocket Furnished by APCo and installed by Customer

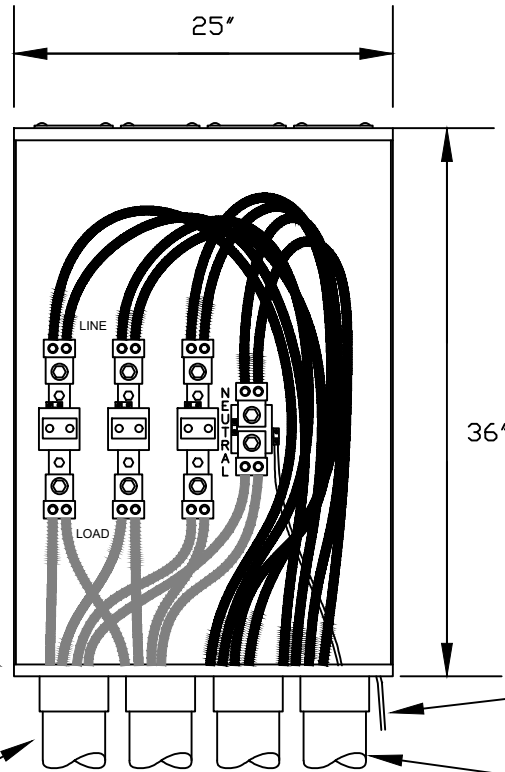

Line connectors are each dual 600 kcm capacity.

Load connectors are each dual 600 kcm capacity.

Four (4) knockouts, each with 3" and 4" knockouts.

Load side conductors, conduit, and adapters furnished and installed by customer

Transocket cover, metering inner panel, and meter wiring omitted for clarity

Grounding electrode conductor, minimum #6 copper, furnished and installed by customer

Line Side:

Pad-Mount: Customer will furnish and install Schedule 40 conduit, adapters and conductors. Schedule 80 building riser conduit required if subject to physical damage.

Pole: Customer will furnish and install Schedule 40 conduit, and adapters. Schedule 80 building riser conduit required if subject to physical damage. Company will furnish and install conductors.

Date

09-26-16

DESCRIPTION Transocket Installation for a Three Phase Underground Service



Alabama Power

A- C-10-5

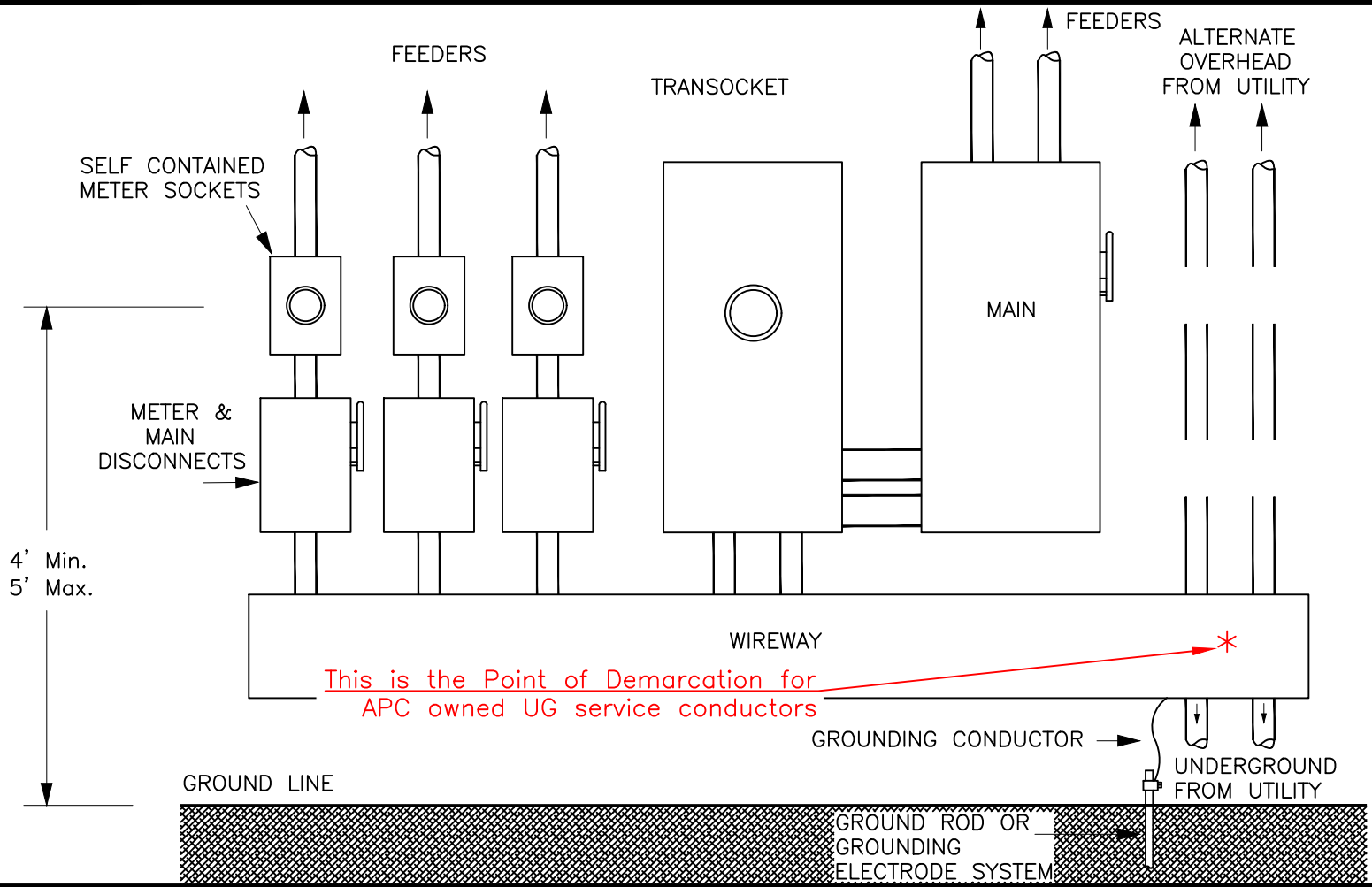
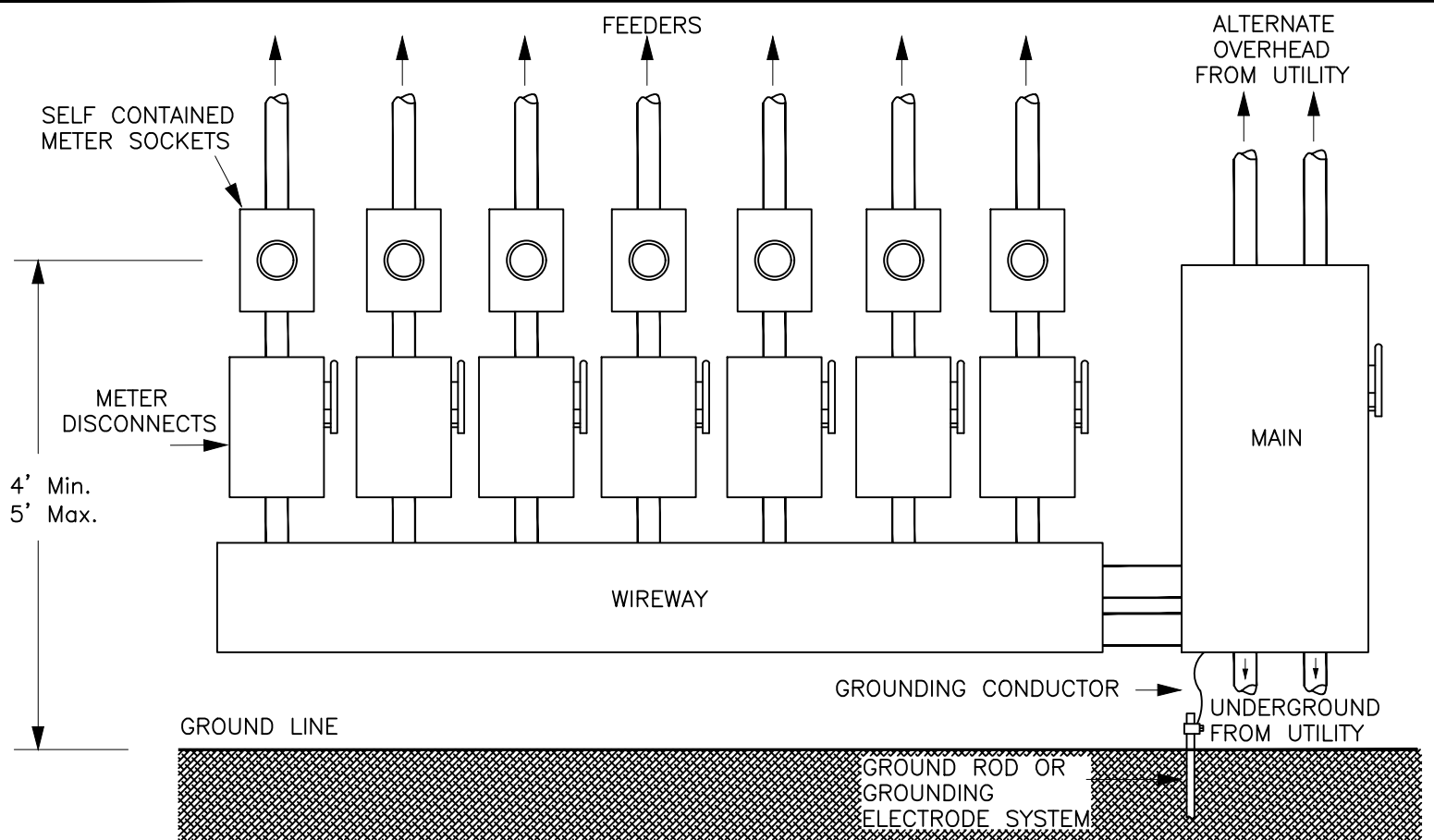

Date	DESCRIPTION	 Alabama Power	A- C-12-1
01-26-22	Typical Installation for Metering Self Contained 277/480 Volt Services		

NOTE: IF DISCONNECTING MEANS CANNOT BE INSTALLED, INSTRUMENT TRANSFORMERS WILL BE USED.

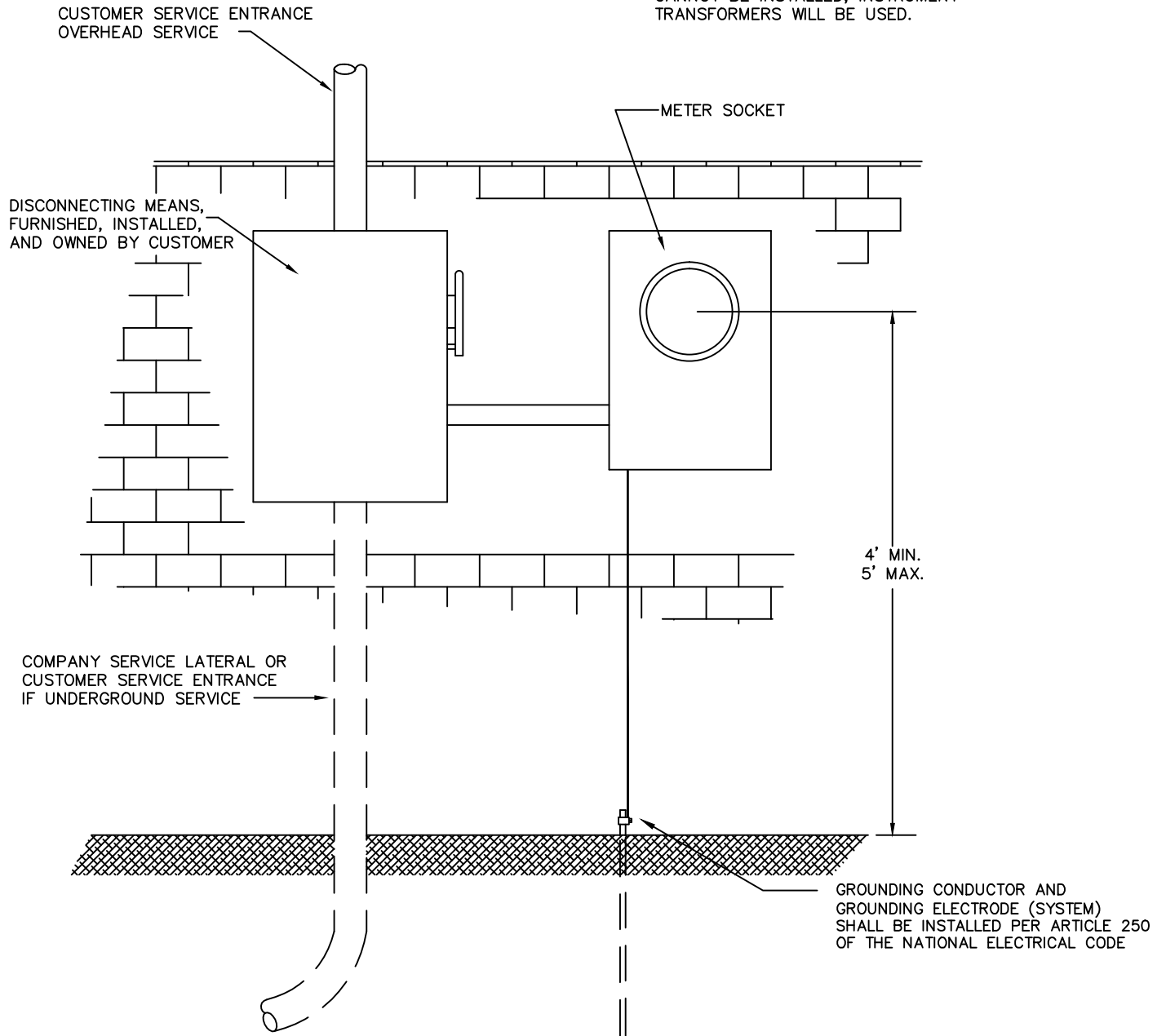

NOTES:

1. To allow de-energizing of the meter for setting and removal, and to avoid interrupting service to others, each 480 volt self-contained meter shall have a load break meter disconnect on the supply side of the meter.
2. Trans-sockets and other instrument rated meter sockets are not required to have a meter disconnect.
3. Each such meter disconnect shall have a short-circuit current rating equal to or greater than the available short circuit current.
4. The meter disconnect(s) may serve as the service equipment, if acceptable to the local inspection authority.
5. The installation must conform to the National Electrical Code and be acceptable to the local inspection authority.
6. The meter disconnect may be locked by the customer.

Date	DESCRIPTION 480 Volt Meter Disconnect	 Alabama Power	A- C-12-2
02-16-10	Requirements		

OVERHEAD SERVICE

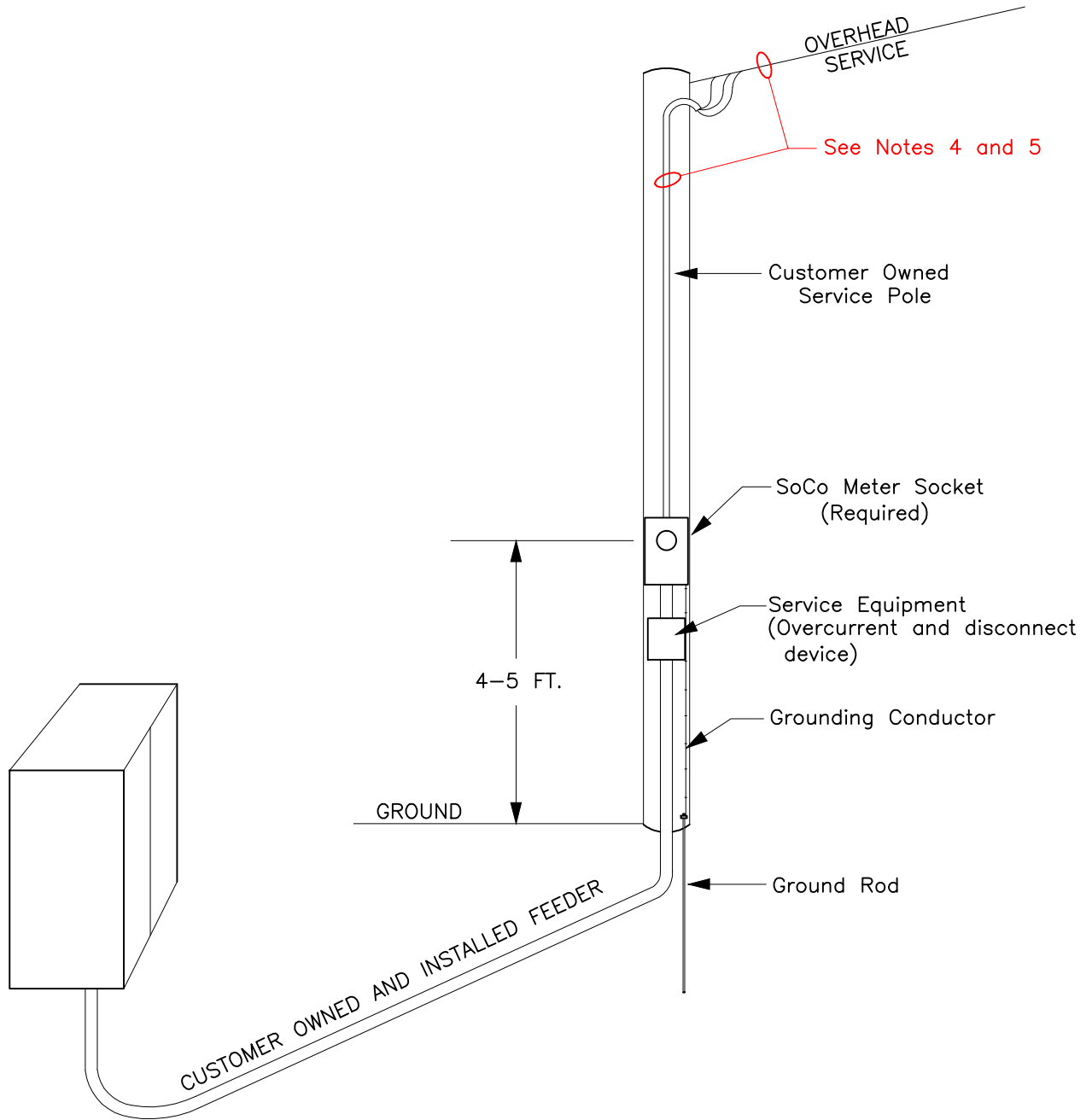

Notes:

1. Service equipment is to be installed on the customer's service pole except as noted in 2.
2. When the power transfer cabinet is within 20 feet of the service pole, the service equipment on the service pole may be omitted provided the power transfer or other cabinet includes an overcurrent and disconnect device(s) that serve as service equipment.
3. The installation of customer owned service equipment must comply with the NEC. See plate C-02-2 for service pole details.
4. A 3-wire overhead service and 3-wire customer service entrance cable to the source side of the meter socket is required.
5. A minimum 60A service entrance using a minimum #6 CU or #4 AL service entrance cable is required.

Date	DESCRIPTION Phone and Cable Company Service	 Alabama Power	A- C-13-1
10-26-15	To Road Side Cabinets – Overhead		

UNDERGROUND FROM A POLE

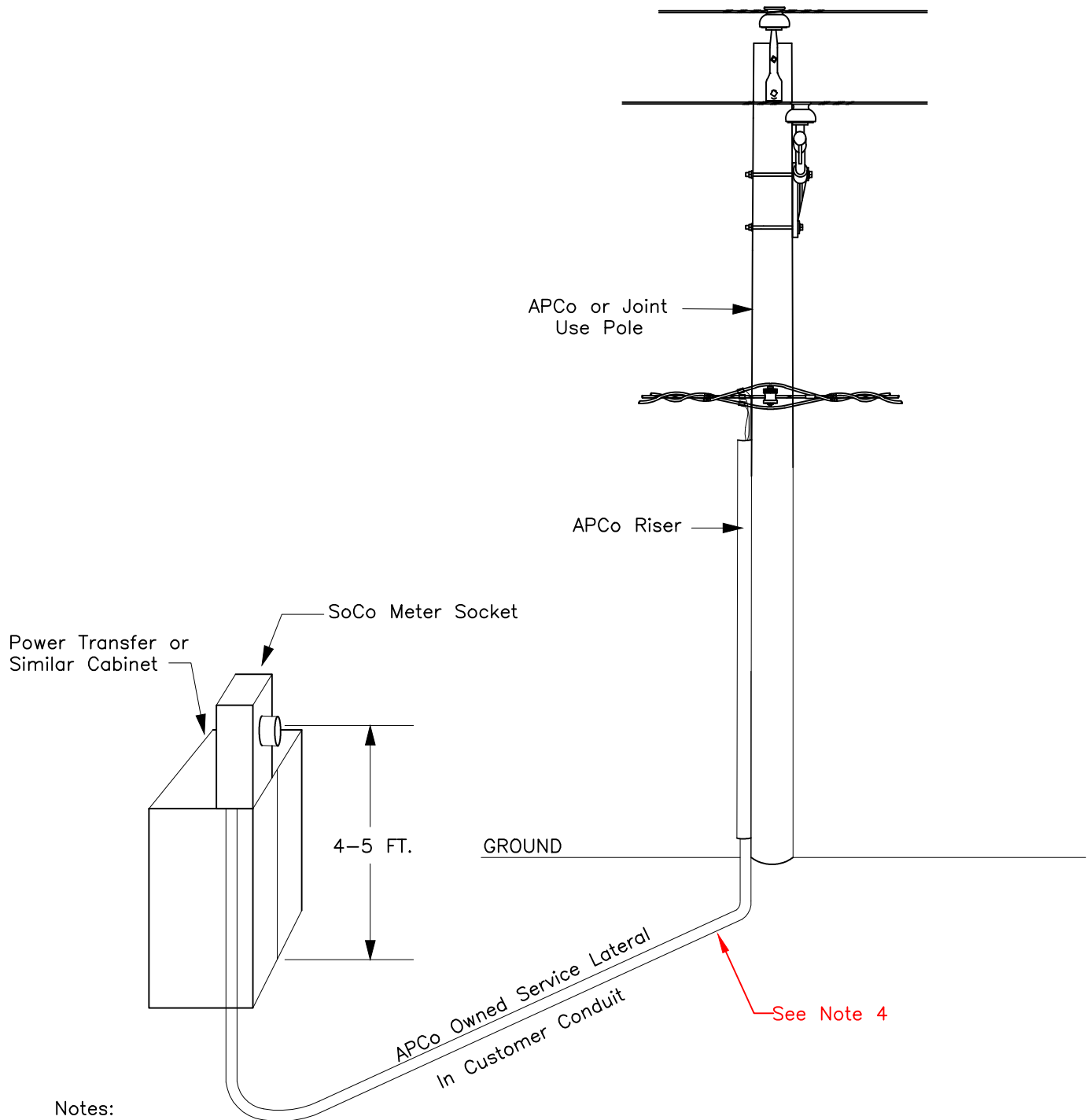

Notes:

1. The underground service lateral from a pole will be installed per **Appendix F of the Rules & Regulations for Electric Service.**
2. The power transfer or other cabinet installation must comply with the NEC. The equipment in the cabinet shall include an overcurrent and disconnect device(s) that serve as the service equipment, or an overcurrent and disconnect device(s) that serve as service equipment shall be installed on the exterior of the cabinet.
3. The conduit shall be 2 inch for a 60 amp entrance, or 3 inch for a 100-200 amp entrance. **Required conduit size is an exception to APCO Rules and Regulations (Appendix F).**
4. **A 3-wire underground service is required.**

Date 10-26-15	DESCRIPTION <u>Phone and Cable Company Service</u> To Road Side Cabinets - Underground	 Alabama Power	A- C-14-1
C-14			

UNDERGROUND FROM A PAD-MOUNTED TRANSFORMER

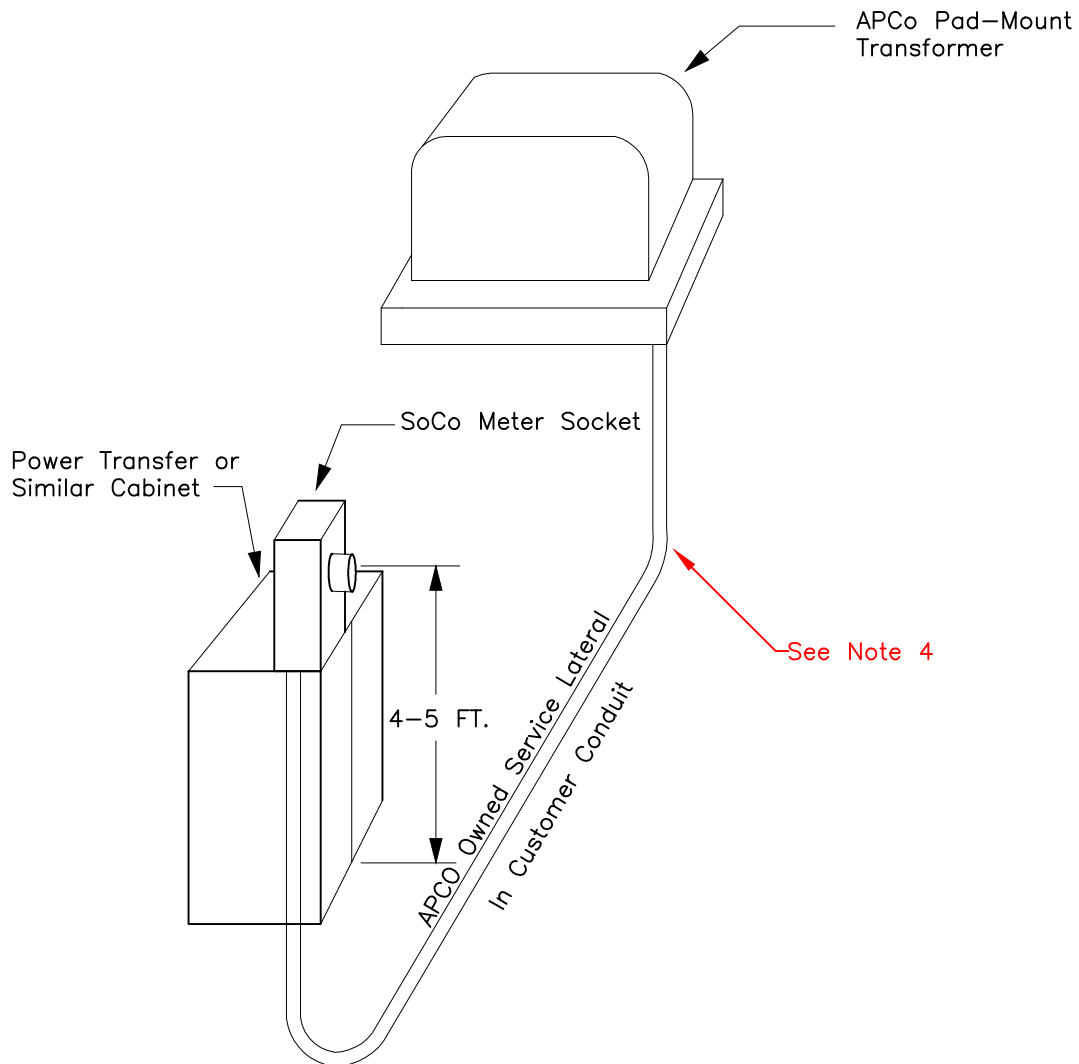

Notes:

1. The underground service lateral from a pad-mounted transformer will be installed per **Appendix F of the Rules & Regulations for Electric Service.**
2. The power transfer or other cabinet installation must comply with the NEC. The equipment in the cabinet shall include an overcurrent and disconnect device(s) that serve as the service equipment, or an overcurrent and disconnect device(s) that serve as service equipment shall be installed on the exterior of the cabinet.
3. The conduit shall be 2 inch for a 60 amp entrance, or 3 inch for a 100-200 amp entrance. **Required conduit size is an exception to APCO Rules and Regulations (Appendix F).**
4. **A 3-wire underground service to the source side of the meter socket is required.**
5. **A minimum 60A service lateral using 3 #6 AL is required.**

Date	DESCRIPTION Phone and Cable Company Service	 Alabama Power	A- C-15-1
10-26-15	To Road Side Cabinets - Underground		

THREE PHASE PAD-MOUNTED TRANSFORMER WITH METERING CT's IN SECONDARY COMPARTMENT AND METER ON FREE-STANDING PEDESTAL

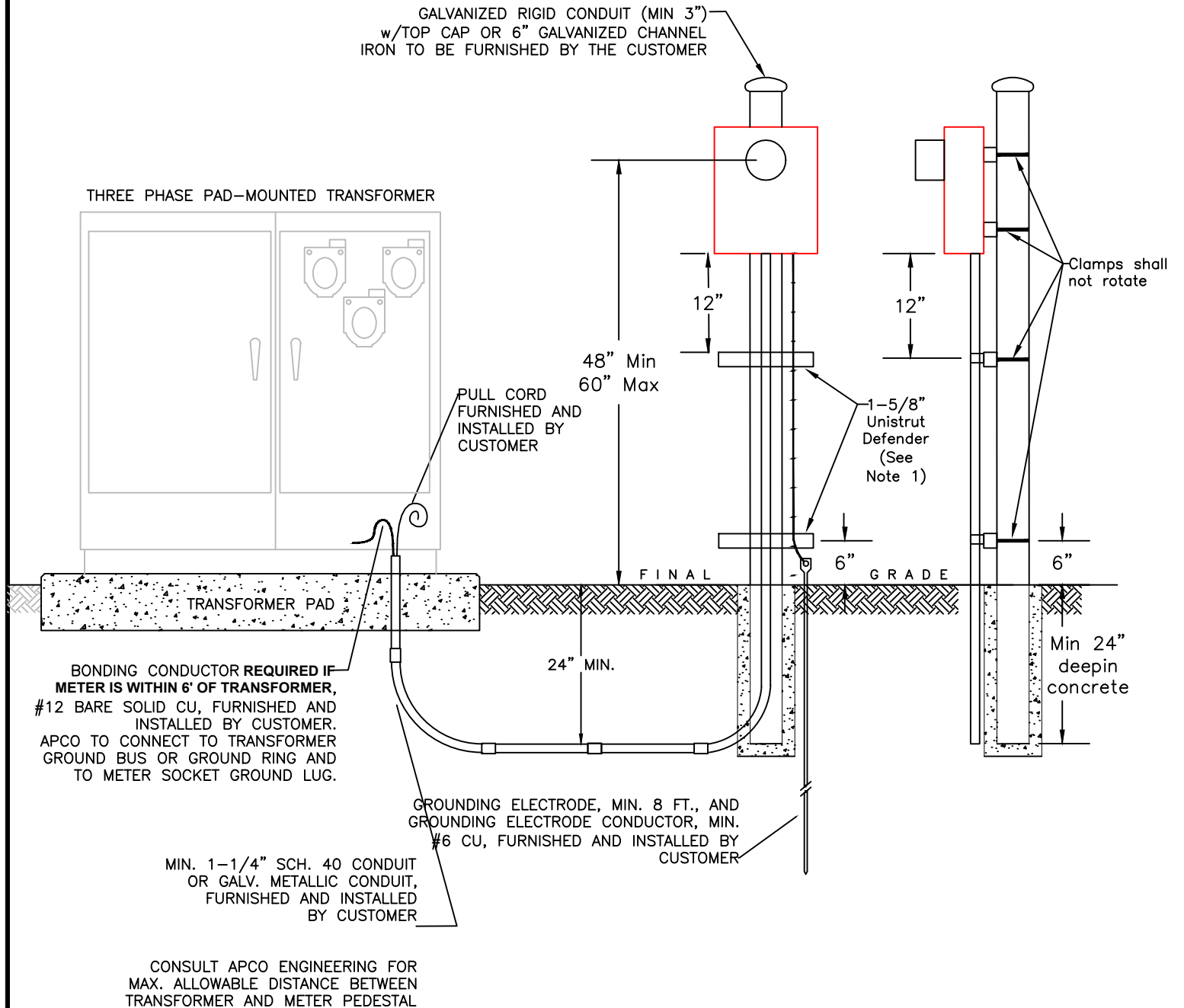

NOTE 1: COMPARABLE PRODUCT TO UNISTRUT DEFENDER IS ACCEPTABLE.

Date

02-21-22

DESCRIPTION Meter Pedestal Near Three Phase
Pad-Mounted Transformer



Alabama Power

A- C-16-1

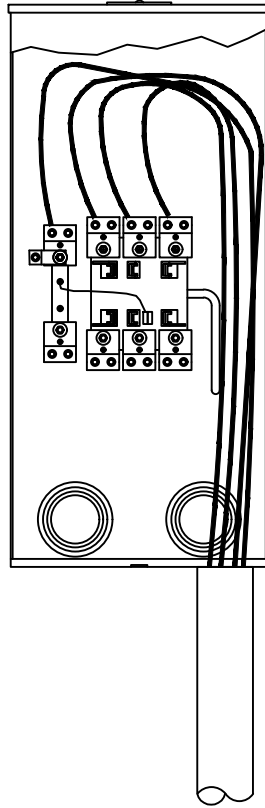

SOCKET 320 AMP THREE PHASE

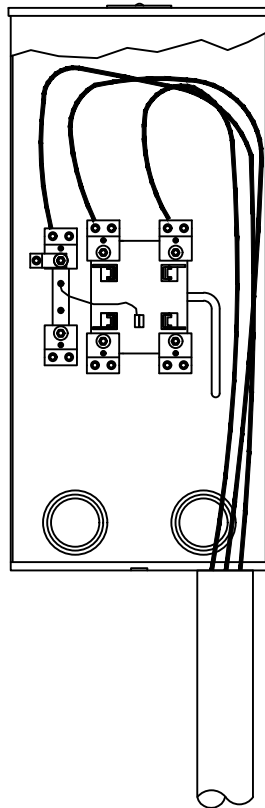

SOCKET 320 AMP SINGLE PHASE

Date

12-06-23

DESCRIPTION UG Riser Entrance for 320A Socket



Alabama Power

A- C-17-1